



ENDOSCOPY
GYNAECOLOGY



Gynäkologie | Gynécologie
Gynaecology | Ginecología
Ginecologia

Katalog
Catalogue
Catalogue
Catálogo
Catalogo

No. **209**

**Kataloge
Catalogues**

**Catalogues
Catálogos
Cataloghi**

SURGERY



Hauptkatalog Chirurgie
Main catalogue surgery
Catalogue général
Catálogo general
Catalogo generale

No. 111



Plastische Chirurgie
Plastic surgery
Chirurgie plastique
Cirugía plástica
Chirurgia plastica

No. 112



Ophthalmologie
Ophthalmology
Ophtalmologie
Oftalmologia
Oftalmologia

No. 113



Traumatologie
Traumatology
Traumatologie
Traumatologia
Traumatologia

No. 114



Gefäßchirurgie
Vascular surgery
Chirurgie vasculaire
Cirugía vascular
Chirurgia vascolare

No. 115



Retraktor Systeme
Retractor systems
Systèmes des écarteurs
Sistema de retractores
Sistemi di retrattori

No. 133



Aneurismen Clips
Aneurysm clips
Clips pour anévrismes
Clips para aneurismas
Clips per aneurismi

No. 134



HNO Hauptkatalog
ENT main catalogue
ORL catalogue général
ORL catálogo general
ORL catalogo generale

No. 501

CONTAINER

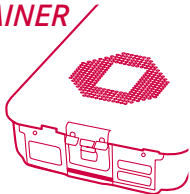

Container I
Container I
Contenaires I
Contenedores I
Container I

No. 302



Container II
Container II
Contenaires II
Contenedores II
Container II

No. 303

OR LIGHTS



ATRIA 1
ATRIA 1
ATRIA 1
ATRIA 1
ATRIA 1

No. 701



ATRIA 2
ATRIA 2
ATRIA 2
ATRIA 2
ATRIA 2

No. 702



ATRIA 3
ATRIA 3
ATRIA 3
ATRIA 3
ATRIA 3

No. 703



ATRIA 5
ATRIA 5
ATRIA 5
ATRIA 5
ATRIA 5

No. 704



ATRIA 7
ATRIA 7
ATRIA 7
ATRIA 7
ATRIA 7

No. 705

Kataloge
Catalogues

Catalogues
Catálogos
Cataloghi

ENDOSCOPY

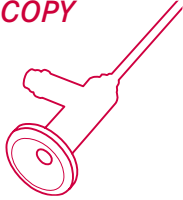

Geräte
Units
Appareils
Equipos
Apparecchi

No. 205

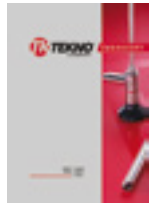

Optiken
Scopes
Optiques
Ópticas
Ottiche

No. 206



Laparoskopie
Laparoscopy
Laparoscopia
Laparoscopia
Laparoscopia

No. 207



Urologie
Urology
Urologie
Urología
Urologia

No. 208



Gynäkologie
Gynaecology
Gynécologie
Ginecología
Ginecologia

No. 209



Arthroskopie
Arthroscopy
Arthroscopia
Artroscopia
Artroscopia

No. 210

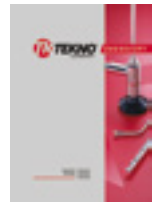

Sinuskopie
Sinuscopy
Sinuscopia
Sinuscopia
Sinuscopia

No. 211

ELECTRO SURGERY

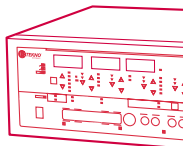

Elektro Chirurgie
Electro surgery
Eléctrochirurgie
Electro-Cirurgia
Elettrobisturi

No. 212

DENTAL



Dental
Dental
Dentaire
Dental
Dentale

No. 402

OR TABLES

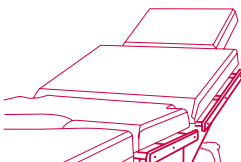

VECTOR 1
VECTOR 1
VECTOR 1
VECTOR 1
VECTOR 1

No. 601



VECTOR 3
VECTOR 3
VECTOR 3
VECTOR 3
VECTOR 3

No. 602



VECTOR 5
VECTOR 5
VECTOR 5
VECTOR 5
VECTOR 5

No. 603



VECTOR 9
VECTOR 9
VECTOR 9
VECTOR 9
VECTOR 9

No. 605



Zubehör
Accessories
Accessoires
Accesorios
Accessori

No. 610

Inhalt | **Contenu**
Content | **Indice**
Indice

| | | | |
|--|--|---|----------------|
|  | <p>Symbole und Besonderheiten, Hysteroskopie <i>Symbols and characteristics, Hysteroscopy</i> Symboles et caractéristiques, Hysteroscopie <i>Símbolos y características, Histeroscopia</i> Simboli e caratteristiche, Isteroscopia</p> | <p>7</p> | |
|  | <p>Hysteroskop System für 2,0 mm Optiken <i>Hysteroscope system for 2.0mm scopes</i> Système d'hysteroscopie pour optiques de 2.0 mm <i>Sistema de histeroscopia para opticas de 2.0 mm</i> Sistema d'isteroscopia per ottiche di 2.0 mm</p> |  | <p>8 - 11</p> |
|  | <p>Hysteroskop System für 2,7/2,9 mm Optiken <i>Hysteroscope system for 2.7/2.9 mm scopes</i> Système d'hysteroscopie pour optiques de 2.7/2.9 mm <i>Sistema de histeroscopia para opticas de 2.7/2.9 mm</i> Sistema d'isteroscopia per ottiche di 2.7/2.9 mm</p> |  | <p>12 - 17</p> |
|  | <p>Hysteroskop System für 4,0 mm Optiken <i>Hysteroscope system for 4.0mm scopes</i> Système d'hysteroscopie pour optiques de 4.0 mm <i>Sistema de histeroscopia para opticas de 4.0 mm</i> Sistema d'isteroscopia per ottiche di 4.0 mm</p> |  | <p>18 - 23</p> |
|  | <p>Flexible Instrumente <i>Flexible instruments</i> Instruments flexibles <i>Instrumentos flexibles</i> Strumenti flessibili</p> | | <p>24 - 28</p> |
|  | <p>Symbole und Besonderheiten, Resektoskopie <i>Symbols and characteristics, Resectoscopy</i> Symboles et caractéristiques, Résectoscopie <i>Símbolos y características, Resectoscopia</i> Simboli e caratteristiche, Resettoscopia</p> | <p>29 - 31</p> | |
|  | <p>Resektoskopie, monopolar <i>Resectoscopy, monopolar</i> Résectoscopie, monopolaire <i>Resectoscopia, monopolar</i> Resettoscopia, monopolare</p> | <p>32 - 39</p> | |

Inhalt | **Contenu**
Content | **Indice**
Indice

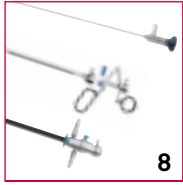

8

Resektoskopie, bipolar
Resectoscopy, bipolar
 Résectoscopie, bipolaire
Resectoscopia, bipolar
 Resettoscopia, bipolare

40 - 50



9

OP-Laparoskope
OP-Laparoscopes
 OP-Laparoscopes
OP-Laparoscopios
 Laparoscopi operativi

51



10

Ring Applikatoren
Ring applicators
 Appicateurs des anneaux
Appicadores de anillos
 Applicatore per anelli

52

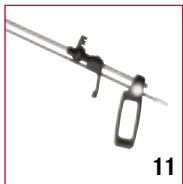

11

Uterusmanipulator
Uterus manipulator
 Manipulator uterin
Manipulador uterino
 Manipolatore uterino

53

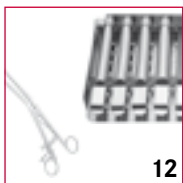

12

Instrumente
Instruments
 Instruments
Instrumentos
 Strumenti

54 - 63



13

Zubehör
Accessories
 Accessoires
Accesorios
 Accessori

64 - 68

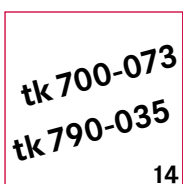

14

Nummernverzeichnis
Numerical index
 Index numérique
Indice numerico
 Indice dei numero d'articolo

69 - 70

Bitte fordern Sie unseren Spezialkatalog an.
Please ask for our special catalogue.
Veuillez demander pour notre catalogue spécial.
Por favor preguntan para el catálogo especial.
Per favore domandate per il nostro catalogo speciale.



MORZELLATOR

MORCELLATOR





Symbole und Besonderheiten
Symbols and characteristics

Symboles et caractéristiques
Símbolos y características
Simboli e caratteristiche

Farberkennung Hysteroskopie
Colour code, hysteroscopy

Marquage en couleur, hysteroscopie
Identificación de color, histeroscopia
Codice colori, isteroscopia

| | |
|------------|---|
| 2.0 mm |  |
| 2.7/2.9 mm |  |
| 4.0 mm |  |

für Optik
for scope

pour optique
para óptica
per ottica

Auch mit Kunststoffhähnen lieferbar
Also available with plastic stopcocks

Aussi disponible avec robinets en plastique
También disponible con llaves en plastica
Anche disponibili con rubinetto in plastica

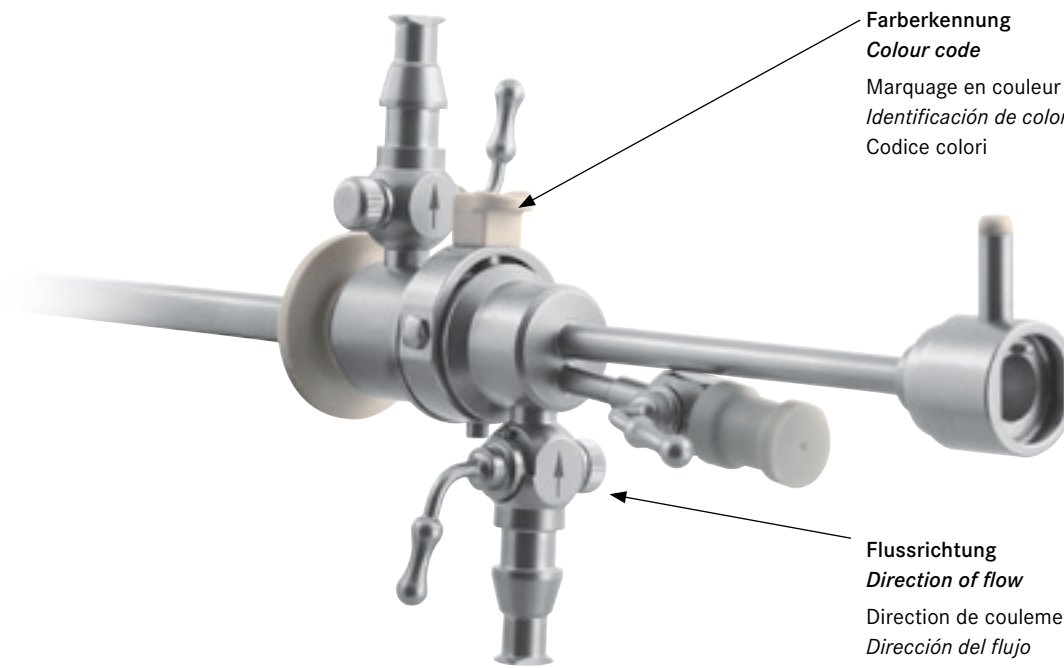
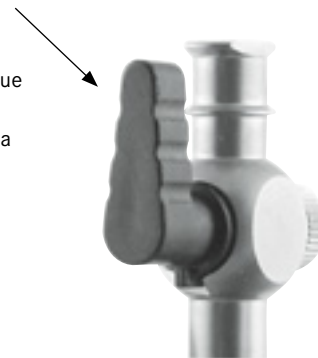

Farberkennung
Colour code
Marquage en couleur
Identificación de color
Codice colori

Flussrichtung
Direction of flow
Direction de coulement
Dirección del flujo
Direzione del flusso

Schaftform
Shape of sheath

Forme de la gaine
Forma de la vaina
Forma della camicia



Oval
Oval
Oval
Ovale
Ovale



Tropfenförmig
Drop shaped
En forme de goutte
En forma de gota
A forma di goccia



Halbrund
Semi circular
Demi-circulaire
Semi circular
Semicircolare



Rund
Round
Ronde
Redondo
Rotondo



Diagnostikschäfte und Hysteroskope
Diagnostic sheaths and hysteroscopes

Gaines pour diagnose et hysteroscopes
Vainas para exploración y hysteroscopios
Camicie diagnostiche e isteroscopi

autoklavierbar / autoclavable
134°C / 273°F - 18 min.

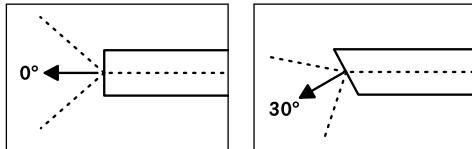

| | | |
|-------------------|-------------------|-------------------|
| Ø 2.0 mm - 260 mm | tk 700-220 | tk 700-221 |
| Ø 2.0 mm - 312 mm | tk 700-226 | tk 700-227 |

Arbeitslänge
Working length
Longueur de travail
Longitud de trabajo
Lunghezza operativa



| | | |
|-----|-------------------|-------------------|
| 0° | Ø 2.6 mm - 235 mm | tk 791-250 |
| 30° | Ø 2.6 mm - 235 mm | tk 791-251 |

für Optik
for scope
pour optique
para óptica
per ottica

Schaft - Arbeitslänge
Sheath - Working length
Gaine - Longueur du travail
Vaina - Longitud de trabajo
Camicia - Lunghezza operativa



tk 791-258

Obturator für tk 791-250 und tk 791-251
Obturator for tk 791-250 and tk 791-251
Obturateur pour tk 791-250 et tk 791-251
Obturator para tk 791-250 y tk 791-251
Otturatore per tk 791-250 e tk 791-251



Diagnostikschäfte
Diagnostic sheaths

Gaines pour diagnose
Vainas para exploración
Camicie diagnostiche



| | |
|-----|-------------------|
| 0° | tk 791-050 |
| 30° | tk 791-051 |

| | |
|------------------------------------|--|
| für Optik <i>for scope</i> | Innenschaft <i>Inner sheath</i> |
| pour optique <i>para óptica</i> | Gaine intérieur <i>Vaina interior</i> |
| per ottica | Camicia interna |



| | | |
|----------|-------------------|-------------------|
| 0° / 30° | Ø 3.4 mm - 200 mm | tk 791-052 |
|----------|-------------------|-------------------|

| | |
|------------------------------------|--|
| für Optik <i>for scope</i> | Außenschaft zur Dauerspülung - Arbeitslänge <i>Outer sheath for continuous flow - Working length</i> |
| pour optique <i>para óptica</i> | Gaine extérieure à irrigation permanente - Longueur du travail <i>Vaina exterior para irrigación continua - Longitud de trabajo</i> |
| per ottica | Camicia esterna a flusso continuo - Lunghezza operativa |

tk 791-053

Obturator für tk 791-050 und tk 791-051
Obturator for tk 791-050 and tk 791-051
Obturateur pour tk 791-050 et tk 791-051
Obturator para tk 791-050 y tk 791-051
Otturatore per tk 791-050 e tk 791-051



Operations-Dauerspülschäfte
Continuous flow operating sheaths

Gaines avec irrigation permanente
Vainas con irrigación y succión continua
Camicie a flusso continuo



| Ø 4.3 mm - 181 mm - 5 Charr.  | Ø 2.0 mm - 30° - 260 mm | tk791-056 | tk791-055 |
|--|--|---|---|
| Operations-Dauerspülschaft <i>Continuous flow operating sheath</i> | für Optik <i>for scope</i> | Außenschaft <i>Outer sheath</i> | Innenschaft <i>Inner sheath</i> |
| Gaine avec irrigation permanente <i>Vaina con irrigación y succión continua</i> Camicia a flusso continuo | pour optique <i>para óptica</i> per ottica | Gaine extérieur <i>Vaina exterior</i> Camicia esterna | Gaine intérieur <i>Vaina interior</i> Camicia interna |
| tk791-042 | | x | x |

komplett
complete
complet
completo
completo



Operationsschäfte
Operating sheaths

Gaines d'operations
Vainas operativas
Camicia operativa



| | | | |
|-------------------------|-------------------|----------|-------------------|
| Ø 2.0 mm - 30° - 260 mm | Ø 4.3 mm - 173 mm | 5 Charr. | tk 791-057 |
| Ø 2.0 mm - 30° - 312 mm | Ø 4.3 mm - 225 mm | 5 Charr. | tk 791-058 |

für Optik
for scope

Schaft - Arbeitslänge
Sheath - Working length

Instrumentenkanal
Instrument channel

pour optique
para óptica
per ottica

Gaine - Longueur du travail
Vaina - Longitud de trabajo
Camicia - Lunghezza operativa

Canal d'instruments
Canal para instrumentos
Canale operativo



Diagnostikschäfte und Hysteroskope
Diagnostic sheaths and hysteroscopes

Gaines pour diagnose et hysteroscopes
Vainas para exploración y hysteroscopios
 Camicie diagnostiche e isteroscopi

autoklavierbar / autoclavable
 134°C / 273°F - 18 min.

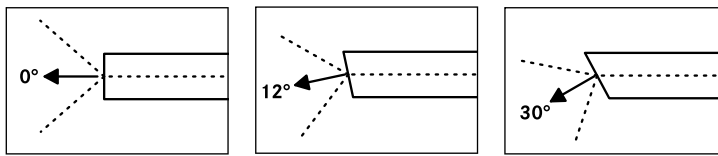

| | | | |
|-------------------|---------------------|---------------------|---------------------|
| Ø 2.7 mm - 302 mm | tk 700-060 | tk 700-062 | tk 700-063 |
| Ø 2.9 mm - 302 mm | tk 700-081 | tk 700-082 | tk 700-085 |
| Ø 2.7 mm - 302 mm | tk 700-060SF | tk 700-062SF | tk 700-063SF |

Ø, Arbeitslänge
 Ø, Working length
 Ø, Longueur de travail
 Ø, Longitud de trabajo
 Ø, Lunghezza operativa

SF = Tekno-Flex
 (see page 68)



| | | |
|-----|-------------------|-------------------|
| 0° | Ø 3.7 mm - 267 mm | tk 791-252 |
| 30° | Ø 3.7 mm - 267 mm | tk 791-253 |

für Optik / for scope / pour optique / para óptica / per ottica
 Schaft - Arbeitslänge / Sheath - Working length / Gaine - Longueur du travail / Vaina - Longitud de trabajo / Camicia - Lunghezza operativa



tk 791-257

Obturator für tk 791-252 und tk 791-253
 Obturator for tk 791-252 and tk 791-253
 Obturateur pour tk 791-252 et tk 791-253
 Obturador para tk 791-252 y tk 791-253
 Otturatore per tk 791-252 e tk 791-253



Diagnostikschäfte
Diagnostic sheaths

Gaines pour diagnose
Vainas para exploración
Camicie diagnostiche



| | |
|-----|-------------------|
| 0° | tk 791-031 |
| 30° | tk 791-030 |

| | |
|--------------|-----------------------|
| für Optik | Innenschaft |
| for scope | <i>Inner sheath</i> |
| pour optique | Gaine intérieure |
| para óptica | <i>Vaina interior</i> |
| per ottica | Camicia interna |



| | | |
|----------|-------------------|-------------------|
| 0° / 30° | Ø 5.0 mm - 240 mm | tk 791-032 |
|----------|-------------------|-------------------|

| | |
|--------------|--|
| für Optik | Außenschaft zur Dauerspülung - Arbeitslänge |
| for scope | <i>Outer sheath for continuous flow - Working length</i> |
| pour optique | Gaine extérieure à irrigation permanente - Longueur du travail |
| para óptica | <i>Vaina exterior para irrigación continua - Longitud de trabajo</i> |
| per ottica | Camicia esterna a flusso continuo - Lunghezza operativa |



tk 791-033

Obturator für tk 791-030 und tk 791-031
Obturator for tk 791-030 and tk 791-031
Obturateur pour tk 791-030 et tk 791-031
Obturator para tk 791-030 y tk 791-031
Otturatore per tk 791-030 e tk 791-031



Operations-Dauerspülschäfte
Continuous flow operating sheaths

Gaines avec irrigation permanente
Vainas con irrigación y succión continua
Camicie a flusso continuo

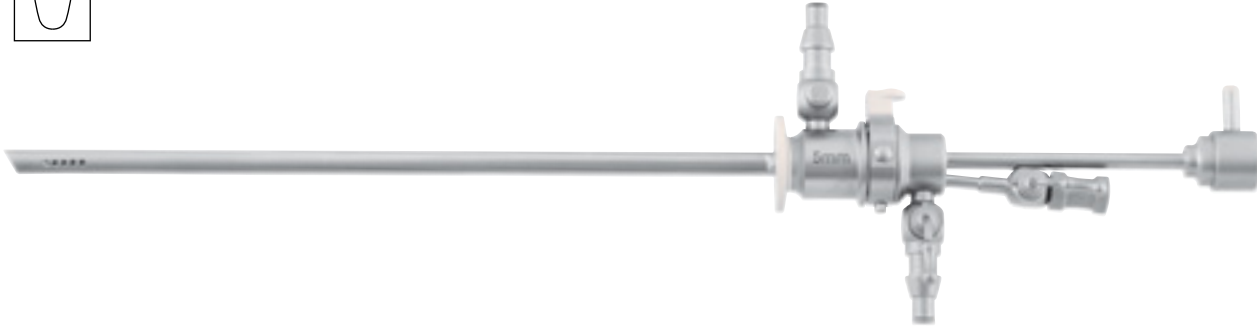

| | | | |
|---|--|---|---|
| Ø 5.0 mm - 192 mm - 5 Charr. <input type="checkbox"/> | 30° | tk 791-034 | tk 791-040 |
| Ø 5.0 mm - 235 mm - 5 Charr. <input type="checkbox"/> | 30° | tk 791-078 | tk 791-079 |
| Ø 6.3 mm - 192 mm - 9 Charr. <input type="checkbox"/> | 30° | tk 791-035 | tk 791-037 |
| Operations-Dauerspülschaft <i>Continuous flow operating sheath</i> | für Optik <i>for scope</i> | Außenschaft <i>Outer sheath</i> | Innenschaft <i>Inner sheath</i> |
| Gaine avec irrigation permanente <i>Vaina con irrigación y succión continua</i> Camicia a flusso continuo | pour optique <i>para óptica</i> per ottica | Gaine extérieur <i>Vaina exterior</i> Camicia esterna | Gaine intérieur <i>Vaina interior</i> Camicia interna |

| | | |
|--|----------|----------|
| tk 791-041 <input type="checkbox"/> | x | x |
| tk 791-077 <input type="checkbox"/> | x | x |
| tk 791-044 <input type="checkbox"/> | x | x |

komplett
complete
complet
completo
completo



Operations-Dauerspülschäfte
Continuous flow operating sheaths

Gaines avec irrigation permanente
Vainas con irrigación y succión continua
Camicie a flusso continuo



| | | | |
|-----|-------------------|----------|-------------------|
| 0° | Ø 6.0 mm - 200 mm | 5 Charr. | tk 791-024 |
| 30° | Ø 6.0 mm - 200 mm | 5 Charr. | tk 791-026 |

| | | |
|--|--|---|
| für Optik <i>for scope</i> | Schaft - Arbeitslänge <i>Sheath - Working length</i> | Instrumentenkanal <i>Instrument channel</i> |
| pour optique <i>para óptica</i> per ottica | Gaine - Longueur du travail <i>Vaina - Longitud de trabajo</i> Camicia - Lunghezza operativa | Canal d'instruments <i>Canal para instrumentos</i> Canale operativo |



| | | |
|-----|----------|-------------------|
| 30° | 5 Charr. | tk 791-080 |
|-----|----------|-------------------|

| | | |
|--|---|--|
| für Optik <i>for scope</i> | Instrumentenkanal <i>Instrument channel</i> | Innenschaft <i>Inner sheath</i> |
| pour optique <i>para óptica</i> per ottica | Canal d'instruments <i>Canal para instrumentos</i> Canale operativo | Gaine intérieure <i>Vaina interior</i> Camicia interna |



| | | |
|-----|-------------------|-------------------|
| 30° | Ø 5.5 mm - 182 mm | tk 791-081 |
|-----|-------------------|-------------------|

| | |
|--|---|
| für Optik <i>for scope</i> | Außenschaft zur Dauerspülung - Arbeitslänge <i>Outer sheath for continuous flow - Working length</i> |
| pour optique <i>para óptica</i> per ottica | Gaine extérieure à irrigation permanente - Longueur du travail <i>Vaina exterior para irrigación continua - Longitud de trabajo</i> Camicia esterna a flusso continuo - Lunghezza operativa |



Operationsschäfte
Operating sheaths

Gaines d'operations
Vainas operativas
Camicia operativa

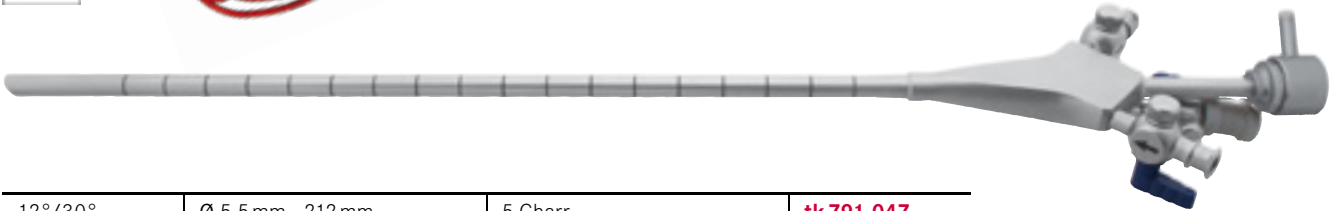
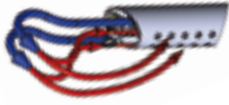

| | | | |
|---------|-------------------|----------|------------|
| 12°/30° | Ø 5.5 mm - 212 mm | 5 Charr. | tk 791-047 |
|---------|-------------------|----------|------------|

| | | |
|--|--|---|
| für Optik <i>for scope</i> | Schaft - Arbeitslänge <i>Sheath - Working length</i> | Instrumentenkanal <i>Instrument channel</i> |
| pour optique <i>para óptica</i> per ottica | Gaine - Longueur du travail <i>Vaina - Longitud de trabajo</i> Camicia - Lunghezza operativa | Canal d'instruments <i>Canal para instrumentos</i> Canale operativo |



| | | | |
|-----|-------------------------|----------|------------|
| 30° | Ø 5.6 x 4.0 mm - 248 mm | 5 Charr. | tk 791-048 |
|-----|-------------------------|----------|------------|

| | | |
|--|--|---|
| für Optik <i>for scope</i> | Schaft - Arbeitslänge <i>Sheath - Working length</i> | Instrumentenkanal <i>Instrument channel</i> |
| pour optique <i>para óptica</i> per ottica | Gaine - Longueur du travail <i>Vaina - Longitud de trabajo</i> Camicia - Lunghezza operativa | Canal d'instruments <i>Canal para instrumentos</i> Canale operativo |



tk 791-049

Obturator für tk 791-048
Obturator for tk 791-048
Obturateur pour tk 791-048
Obturator para tk 791-048
Otturatore per tk 791-048



Operationsschäfte
Operating sheaths

Gaines d'operations
Vainas operativas
Camicia operativa



| | | |
|-----|----------|-------------------|
| 30° | 5 Charr. | tk 791-045 |
|-----|----------|-------------------|

| | | |
|---|--|---|
| für Optik <i>for scope</i> pour optique <i>para óptica</i> per ottica | 2 Instrumentenkanäle <i>2 Instrument channels</i> 2 Canaux d'instruments <i>2 Canales para instrumentos</i> 2 Canale operativi | Innenschaft <i>Inner sheath</i> Gaine intérieur <i>Vaina interior</i> Camicia interna |
|---|--|---|



| | | |
|-----|-----------------|-------------------|
| 30° | Ø 6.5mm - 210mm | tk 791-046 |
|-----|-----------------|-------------------|

| | |
|---|--|
| für Optik <i>for scope</i> pour optique <i>para óptica</i> per ottica | Außenschaft zur Dauerspülung - Arbeitslänge <i>Outer sheath for continuous flow - Working length</i> Gaine extérieure à irrigation permanente - Longueur du travail <i>Vaina exterior para irrigación continua - Longitud de trabajo</i> Camicia esterna a flusso continuo - Lunghezza operativa |
|---|--|



Diagnostikschäfte und Hysteroskope
Diagnostic sheaths and hysteroscopes

Gaines pour diagnose et hysteroscopes
Vainas para exploración y hysteroscopios
Camicie diagnostiche e isteroscopi

autoklavierbar / autoclavable
134°C / 273°F - 18 min.

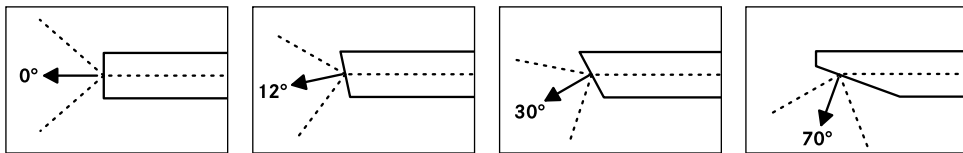

| | | | | |
|-------------------|---------------------|---------------------|---------------------|---------------------|
| Ø 4.0 mm - 302 mm | tk 700-070 | tk 700-072 | tk 700-073 | tk 700-077 |
| Ø 4.0 mm - 302 mm | tk 700-070SF | tk 700-072SF | tk 700-073SF | tk 700-077SF |

Arbeitslänge

Working length

Longueur de travail

Longitud de trabajo

Lunghezza operativa

SF = Tekno-Flex
(see page 68)

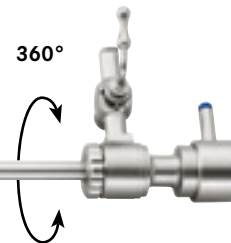

| | | |
|-----|-------------------|-------------------|
| 0° | Ø 5.0 mm - 267 mm | tk 791-131 |
| 30° | Ø 5.0 mm - 267 mm | tk 791-130 |

für Optik

for scope

pour optique

para óptica

per ottica

Schaft - Arbeitslänge

Sheath - Working length

Gaine - Longueur du travail

Vaina - Longitud de trabajo

Camicia - Lunghezza operativa



tk 791-256

Obturator für tk 791-130 und tk 791-131

Obturator for tk 791-130 and tk 791-131

Obturateur pour tk 791-130 et tk 791-131

Obturator para tk 791-130 y tk 791-131

Otturatore per tk 791-130 e tk 791-131



Diagnostikschäfte
Diagnostic sheaths

Gaines pour diagnose
Vainas para exploración
Camicie diagnostiche



| | |
|-----------|-------------------|
| 0° / 12° | tk 791-137 |
| 12° / 30° | tk 791-132 |

für Optik
for scope
pour optique
para óptica
per ottica

Innenschaft - Arbeitslänge
Inner sheath - Working length
Gaine intérieur - Longueur du travail
Vaina interior - Longitud de trabajo
Camicia interna - Lunghezza operativa



| | | |
|----------------|-------------------|-------------------|
| 0° / 12° / 30° | Ø 6.5 mm - 240 mm | tk 791-133 |
|----------------|-------------------|-------------------|

für Optik
for scope
pour optique
para óptica
per ottica

Außenschaft zur Dauerspülung - Arbeitslänge
Outer sheath for continuous flow - Working length
Gaine extérieure à irrigation permanente - Longueur du travail
Vaina exterior para irrigación continua - Longitud de trabajo
Camicia esterna a flusso continuo - Lunghezza operativa



tk 791-138





Obturator für tk 791-132 und tk 791-137
Obturator for tk 791-132 and tk 791-137
Obturateur pour tk 791-132 et tk 791-137
Obturator para tk 791-132 y tk 791-137
Otturatore per tk 791-132 e tk 791-137



Operations-Dauerspülschäfte
Continuous flow operating sheaths

Gaines avec irrigation permanente
Vainas con irrigación y succión continua
Camicie operative a flusso continuo



| | | | |
|---|--|---|---|
| Ø 6.5 mm – 192 mm – 5 Charr.  | 30° | tk 791-064 | tk 791-065 |
| Ø 7.0 mm – 192 mm – 7 Charr.  | 30° | tk 791-061 | tk 791-060 |
| Operations-Dauerspülschaft <i>Continuous flow operating sheath</i> | für Optik <i>for scope</i> | Außenschaft <i>Outer sheath</i> | Innenschaft <i>Inner sheath</i> |
| Gaine avec irrigation permanente <i>Vaina con irrigación y succión continua</i> Camicia a flusso continuo | pour optique <i>para óptica</i> per ottica | Gaine extérieur <i>Vaina exterior</i> Camicia esterna | Gaine intérieur <i>Vaina interior</i> Camicia interna |
| tk 791-063  | | x | x |
| tk 791-043  | | x | x |

komplett
complete
complet
completo
completo



Operations-Dauerspülschäfte
Continuous flow operating sheaths

Gaines avec irrigation permanente
Vainas con irrigación y succión continua
Camicie operative a flusso continuo



| | | |
|------------------------------------|---|--|
| 30° | 7 Charr. | tk 791-140 |
| für Optik <i>for scope</i> | Instrumentenkanal <i>Instrument channel</i> | Innenschaft <i>Inner sheath</i> |
| pour optique <i>para óptica</i> | Canal d'instruments <i>Canal para instrumentos</i> | Gaine intérieur <i>Vaina interior</i> |
| per ottica | Canale operativo | Camicia interna |



| | | |
|------------------------------------|--|-------------------|
| 30° | Ø 7.0 mm - 182 mm | tk 791-134 |
| für Optik <i>for scope</i> | Außenschaft zur Dauerspülung - Arbeitslänge <i>Outer sheath for continuous flow - Working length</i> | |
| pour optique <i>para óptica</i> | Gaine extérieure à irrigation permanente - Longueur du travail <i>Vaina exterior para irrigación continua - Longitud de trabajo</i> | |
| per ottica | Camicia esterna a flusso continuo - Lunghezza operativa | |



tk 791-136

Obturator für tk 791-134
Obturator for tk 791-134
Obturateur pour tk 791-134
Obturator para tk 791-134
Otturatore per tk 791-134



Operationsschäfte
Operating sheaths

Gaines d'operations
Vainas operativas
Camicie operativa

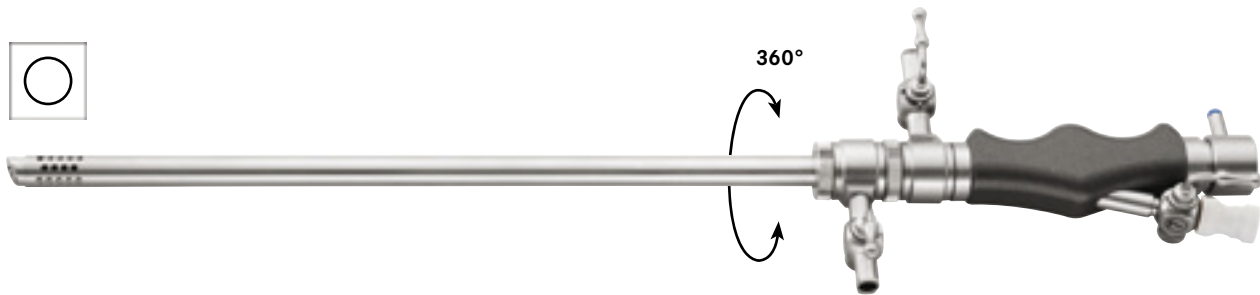

| | | | |
|-----|-------------------|----------|------------|
| 0° | Ø 8.0 mm - 200 mm | 7 Charr. | tk 791-070 |
| 30° | Ø 8.0 mm - 200 mm | 7 Charr. | tk 791-072 |

für Optik
for scope

Schaft zur Dauerspülung - Arbeitslänge
Sheath for continuous flow - Working length

Instrumentenkanal
Instrument channel

pour optique
para óptica
per ottica

Gaine à irrigation permanente - Longueur du travail
Vaina para irrigación continua - Longitud de trabajo
Camicia per flusso continuo - Lunghezza operativa

Canal d'instruments
Canal para instrumentos
Canale operativo

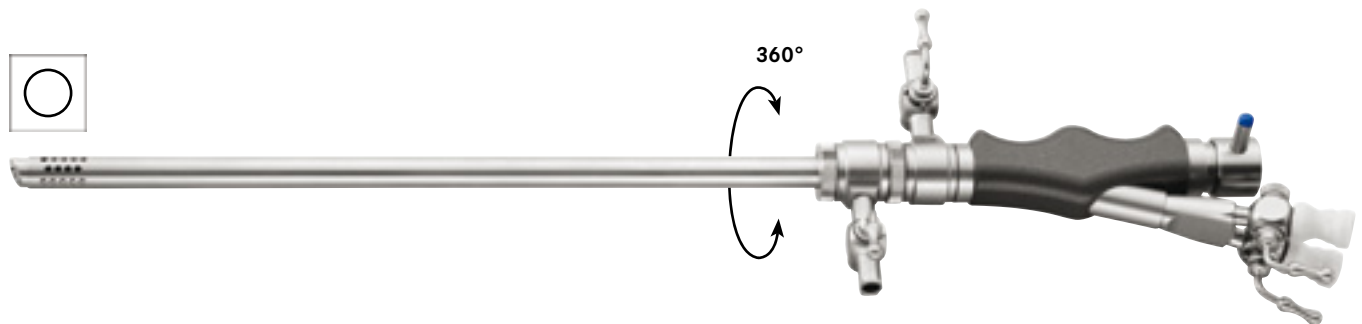

| | | | |
|-----|-------------------|----------|------------|
| 0° | Ø 8.0 mm - 200 mm | 7 Charr | tk 791-074 |
| 30° | Ø 8.0 mm - 200 mm | 7 Charr. | tk 791-076 |

für Optik
for scope

Schaft zur Dauerspülung - Arbeitslänge
Sheath for continuous flow - Working length

2 Instrumentenkanäle
2 Instrument channels

pour optique
para óptica
per ottica

Gaine à irrigation permanente - Longueur du travail
Vaina para irrigación continua - Longitud de trabajo
Camicia per flusso continuo - Lunghezza operativa

2 Canal d'instruments
2 Canal para instrumentos
2 Canale operativi



Arbeitseinsatz | Insert de travail
Working insert | *Elemento de trabajo*
 Elemento operativo

Arbeitseinsatz mit ALBARRAN Lenkhebel und 1 Instrumentenkanal
Working insert with ALBARRAN deflecting mechanism and 1 instrument channel

Insert de travail ALBARRAN avec 1 canal d'instrument
Inserto de trabajo ALBARRAN con 1 canal de instrumento
 Elemento operativo ALBARRAN ad 1 canale operativo



| | | |
|------------------------------------|---|---|
| 0°/12°/30°/70° | 7 Charr | tk 791-144 |
| für Optik <i>for scope</i> | Instrumentenkanal <i>Instrument channel</i> | Innenschaft <i>Inner sheath</i> |
| pour optique <i>para óptica</i> | Canal d'instruments <i>Canal para instrumentos</i> | Gaine intérieure <i>Vaina interior</i> |
| per ottica | Canale operativo | Camicia interna |



| | | |
|------------------------------------|---|-------------------|
| 0°/12°/30°/70° | Ø 8.0 mm - 185 mm | tk 791-142 |
| für Optik <i>for scope</i> | Außenschaft - Arbeitslänge <i>Outer sheath - Working length</i> | |
| pour optique <i>para óptica</i> | Gaine extérieure - Longueur du travail <i>Vaina exterior - Longitud de trabajo</i> | |
| per ottica | Camicia esterna - Lunghezza operativa | |



tk 791-143

Obturator für tk 791-142
Obturator for tk 791-142
 Obturateur pour tk 791-142
Obturador para tk 791-142
 Otturatore per tk 791-142

Flexible Instrumente
Flexible instruments

 Instruments flexibles
Instrumentos flexibles
 Strumenti flessibili

| | | | | |
|----------|--------|-------------------|-------------------|-------------------|
| 5 Charr. | 400 mm | tk 790-219 | tk 790-199 | tk 790-239 |
| 7 Charr. | 400 mm | tk 790-226 | tk 790-206 | tk 790-246 |
| 9 Charr. | 400 mm | tk 790-227 | tk 790-207 | tk 790-247 |

| | | | | |
|--|---|---|--|---|
| Fasszange, Alligatormaul <i>Grasping forceps, alligator jaw</i> | Arbeitslänge <i>Working length</i> | halbstarr <i>semi-rigid</i> | flexibel <i>flexible</i> | flexibel und isoliert <i>flexible and insulated</i> |
| Pince à saisir, mors crocodil <i>Pinza de agarre con dientes de cocodrilo</i> <i>Pinza da presa con morso a cocodrillo</i> | Longueur de travail <i>Longitud de trabajo</i> <i>Lunghezza operativa</i> | semi-rigide <i>semi-rigido</i> <i>semi rigida</i> | flexible <i>flexible</i> <i>flessibile</i> | flexible isolée <i>flexible con aislamiento</i> <i>flessibile e isolata</i> |



| | | | | |
|----------|--------|-------------------|-------------------|-------------------|
| 5 Charr. | 400 mm | tk 790-217 | tk 790-197 | tk 790-237 |
| 7 Charr. | 400 mm | tk 790-222 | tk 790-202 | tk 790-242 |
| 9 Charr. | 400 mm | tk 790-223 | tk 790-203 | tk 790-243 |

| | | | | |
|---|---|---|--|---|
| Biopsiezange, Löffel oval <i>Biopsy forceps, oval spoon</i> | Arbeitslänge <i>Working length</i> | halbstarr <i>semi-rigid</i> | flexibel <i>flexible</i> | flexibel und isoliert <i>flexible and insulated</i> |
| Pince à biopsie, mors oval <i>Pinza para biopsia, cuchara oval</i> <i>Pinza da biopsia a cucciaio ovale</i> | Longueur de travail <i>Longitud de trabajo</i> <i>Lunghezza operativa</i> | semi-rigide <i>semi-rigido</i> <i>semi rigida</i> | flexible <i>flexible</i> <i>flessibile</i> | flexible isolée <i>flexible con aislamiento</i> <i>flessibile e isolata</i> |



| | | | | |
|----------|--------|-------------------|-------------------|-------------------|
| 5 Charr. | 400 mm | tk 790-218 | tk 790-198 | tk 790-238 |
| 7 Charr. | 400 mm | tk 790-224 | tk 790-204 | tk 790-244 |
| 9 Charr. | 400 mm | tk 790-225 | tk 790-205 | tk 790-245 |

| | | | | |
|--|---|---|--|---|
| Biopsiezange, Löffel oval, gezahnt <i>Biopsy forceps, oval spoon, serrated</i> | Arbeitslänge <i>Working length</i> | halbstarr <i>semi-rigid</i> | flexibel <i>flexible</i> | flexibel und isoliert <i>flexible and insulated</i> |
| Pince à biopsie, mors oval, dentelée <i>Pinza para biopsia, cuchara oval, dentado</i> <i>Pinza da biopsia a cucciaio ovale, dentellata</i> | Longueur de travail <i>Longitud de trabajo</i> <i>Lunghezza operativa</i> | semi-rigide <i>semi-rigido</i> <i>semi rigida</i> | flexible <i>flexible</i> <i>flessibile</i> | flexible isolée <i>flexible con aislamiento</i> <i>flessibile e isolata</i> |

Flexible Instrumente
*Flexible instruments*Instruments flexibles
Instrumentos flexibles
Strumenti flessibili

| | | | | |
|--------------------------------------|--|--|---|--|
| 5 Charr. | 400 mm | tk 790-216 | tk 790-196 | tk 790-236 |
| 7 Charr. | 400 mm | tk 790-220 | tk 790-200 | tk 790-240 |
| 9 Charr. | 400 mm | tk 790-221 | tk 790-201 | tk 790-241 |
| Scheren <i>Scissors</i> | Arbeitslänge <i>Working length</i> | halbstarr <i>semi-rigid</i> | flexibel <i>flexible</i> | flexibel und isoliert <i>flexible and insulated</i> |
| Ciseaux <i>Tijeras</i> Forbice | Longueur de travail <i>Longitud de trabajo</i> Lunghezza operativa | semi-rigide <i>semi-rigido</i> semi rigida | flexible <i>flexible</i> flessibile | flexible isolée <i>flexible con aislamiento</i> flessibile e isolata |



| | | | | |
|--------------------------------------|--|--|---|--|
| 7 Charr. | 400 mm | tk 790-263 | tk 790-262 | tk 790-264 |
| Scheren <i>Scissors</i> | Arbeitslänge <i>Working length</i> | halbstarr <i>semi-rigid</i> | flexibel <i>flexible</i> | flexibel und isoliert <i>flexible and insulated</i> |
| Ciseaux <i>Tijeras</i> Forbice | Longueur de travail <i>Longitud de trabajo</i> Lunghezza operativa | semi-rigide <i>semi-rigido</i> semi rigida | flexible <i>flexible</i> flessibile | flexible isolée <i>flexible con aislamiento</i> flessibile e isolata |



| | | | | |
|--|--|--|---|--|
| 7 Charr. | 400 mm | tk 790-255 | tk 790-250 | tk 790-258 |
| 9 Charr. | 400 mm | tk 790-256 | tk 790-251 | tk 790-260 |
| Hakenscheren <i>Hook scissors</i> | Arbeitslänge <i>Working length</i> | halbstarr <i>semi-rigid</i> | flexibel <i>flexible</i> | flexibel und isoliert <i>flexible and insulated</i> |
| Ciseaux à crochet <i>Tijeras de gancho</i> Forbice ad uncino | Longueur de travail <i>Longitud de trabajo</i> Lunghezza operativa | semi-rigide <i>semi-rigido</i> semi rigida | flexible <i>flexible</i> flessibile | flexible isolée <i>flexible con aislamiento</i> flessibile e isolata |



Andere Längen und Durchmesser auf Anfrage
Other lengths and diameters on request

Autres longueurs et diamètres sur demande
Otras longitudes y diámetros sobre demanda

Altre lunghezze ed altri diametri disponibili su richiesta



Flexible Elektroden
Flexible electrodes

Electrodes flexibles
Electrodos flexibles
Elettrodi flessibili



| | | | |
|--------------------|-------------------|-------------------|-------------------|
| 3 Charr. - 450 mm | tk 790-482 | tk 790-487 | - |
| 4 Charr. - 450 mm | tk 790-483 | tk 790-488 | - |
| 5 Charr. - 450 mm | tk 790-280 | tk 790-284 | tk 790-288 |
| 6 Charr. - 450 mm | tk 790-282 | - | - |
| 7 Charr. - 450 mm | tk 790-281 | tk 790-285 | tk 790-289 |
| 8 Charr. - 450 mm | tk 790-484 | - | - |
| 9 Charr. - 450 mm | tk 790-485 | - | tk 790-495 |
| 10 Charr. - 450 mm | tk 790-486 | - | tk 790-496 |

| | | | |
|--------------------|-------------------|-------------------|-------------------|
| 3 Charr. - 650 mm | tk 790-170 | tk 790-177 | - |
| 4 Charr. - 650 mm | tk 790-171 | tk 790-178 | - |
| 5 Charr. - 650 mm | tk 790-172 | tk 790-179 | tk 790-186 |
| 6 Charr. - 650 mm | tk 790-169 | - | - |
| 7 Charr. - 650 mm | tk 790-173 | tk 790-180 | tk 790-187 |
| 8 Charr. - 650 mm | tk 790-174 | - | - |
| 9 Charr. - 650 mm | tk 790-175 | - | tk 790-189 |
| 10 Charr. - 650 mm | tk 790-176 | - | tk 790-194 |

Arbeitslänge
Working length

Kugelelektrode
Ball electrode

Nadelelektrode
Needle electrode

Schlingenelektrode
Loop electrode

Longueur de travail
Longitud de trabajo
Lunghezza operativa

Electrode à boule
Electrodo de bola
Elettrodo a pallina

Electrode à aiguille
Electrodo de aguja
Elettrodo a ago

Electrode de asa
Electrodo de lazo
Elettrodo ad ansa



| | | |
|----------|----|-------------------|
| Ø = 4 mm | 3m | tk 790-310 |
|----------|----|-------------------|

Aesculap, Berchtold, Martin



| | | |
|----------|----|-------------------|
| Ø = 5 mm | 3m | tk 790-311 |
|----------|----|-------------------|

Storz, Erbe



| | | |
|----------|----|-------------------|
| Ø = 8 mm | 3m | tk 790-312 |
|----------|----|-------------------|

Tekno, Valleylab, Bovie



| | | |
|----------|----|-------------------|
| Ø = 4 mm | 3m | tk 790-313 |
|----------|----|-------------------|

Berchtold, Martin





Flexible Elektroden
Flexible electrodes

Electrodes flexibles
Electrodos flexibles
Elettrodi flessibili



| 5 Charr. - 360 mm | tk 790-150 | tk 790-151 | tk 790-152 | tk 790-153 |
|---|---|---|---|--|
| Arbeitslänge <i>Working length</i> | Kugelelektrode <i>Ball electrode</i> | Nadelelektrode <i>Needle electrode</i> | Nadelelektrode <i>Needle electrode</i> | Hakenelektrode 90° <i>Hook electrode 90°</i> |
| Longueur de travail <i>Longitud de trabajo</i> | Electrode à boule <i>Electrodo de bola</i> | Electrode à aiguille <i>Electrodo de aguja</i> | Electrode à aiguille <i>Electrodo de aguja</i> | Electrode de crochet 90° <i>Electrodo de gancho 90°</i> |
| Lunghezza operativa | Elettrodo a pallina | Elettrodo ad ago | Elettrodo ad ago | Elettrodo ad uncino 90° |

| | | | | | |
|--|--|----|-------------------|------------------|--|
| | Erbe ICC/ACC, Wisap, Storz | 3m | tk 707-330 | Flat plug round | |
| | | 3m | tk 707-300 | Flat plug square | |
| | Martin, Berchtold | 3m | tk 707-331 | Flat plug round | |
| | | 3m | tk 707-301 | Flat plug square | |
| | TEKNO, Valleylab USA | 3m | tk 707-332 | Flat plug round | |
| | | 3m | tk 707-302 | Flat plug square | |
| | TEKNO, Valleylab Europe | 3m | tk 707-333 | Flat plug round | |
| | | 3m | tk 707-303 | Flat plug square | |
| | TEKNO, 19 mm for TOM 80/100 /212/212A/ 412/412A only | 3m | tk 707-338 | Flat plug round | |

Bitte fragen Sie nach unserem TOM 100 Gerät, speziell konzipiert für den bipolaren Einsatz in der Gynäkologie
Please ask for our TOM 100 unit, especially created for bipolar use in gynaecology

Veuillez demander pour modèle TOM 100, spécialement conçu pour l'utilisation bipolaire en gynécologie
Pregunta Ud. para nuestro modelo TOM 100, planeado especialmente para el uso bipolar en ginecología

Per favore richiedete il nostro apparecchio TOM 100, specialmente progettato per l'uso bipolare in ginecologia.



Bitte fordern Sie unseren Spezialkatalog an.
Please ask for our special catalogue.
Veuillez demander pour notre catalogue spécial.
Por favor preguntan para el catálogo especial.
Per favore domandate per il nostro catalogo speciale.



HF-GERÄT TOM 500



HF-UNIT TOM 500

Symbole und Besonderheiten
Symbols and characteristics

Symboles et caractéristiques
Símbolos y características
Simboli e caratteristiche

Farberkennung für jeweilige Charr.
Colour code for respective Charr.

Marquage en couleur pour respectives Charr.
Identificación de color para cada Charr.
Identificazione a colori per i relativi Charr.

| | |
|----------------|---|
| 19/22 Charr. |  |
| 24/26 Charr. |  |
| 27/28,5 Charr. |  |

Auch mit Kunststoffhähnen lieferbar
Also available with plastic stopcocks
Aussi disponible avec robinets en plastique
También disponible con llaves en plastica
Anche disponibili con rubinetto in plastica

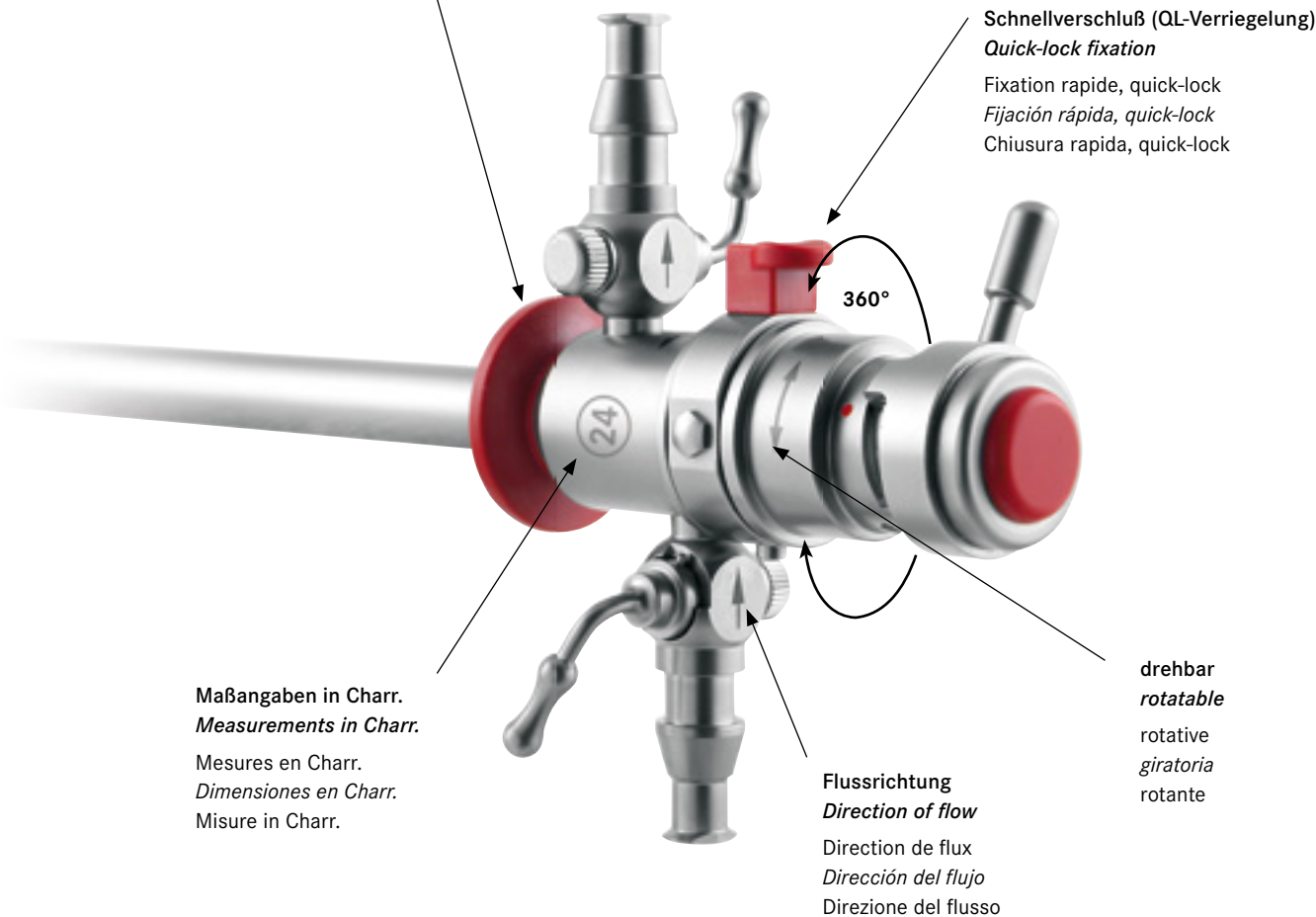

 = Durchmesser Aussenschaft
Outer diameter sheath
Diamètre de la gaine externe
Diametro de la vaina externa
Diametro camicia esterna

 = Durchmesser Innenschaft
Inner diameter sheath
Diamètre de la gaine interne
Diametro de la vaina interna
Diametro camicia interna

Systemübersicht
System overview

Aperçu général du système
Vista general del sistema
Visione sul sistema

| | |
|----------------------|---|
| ⊙ 19 / ⊙ 22 Charr. | ■ |
| ⊙ 24 / ⊙ 26 Charr. | ■ |
| ⊙ 27 / ⊙ 28.5 Charr. | ■ |

| | |
|--|-------------------------|
| | Elektroden |
| | Electrodes |
| | Electrodes |
| | Electrodos |
| | Elettrodi |
| | tk 791-420 - tk 791-423 |
| | tk 791-350 - tk 791-365 |
| | tk 791-450 - tk 791-465 |

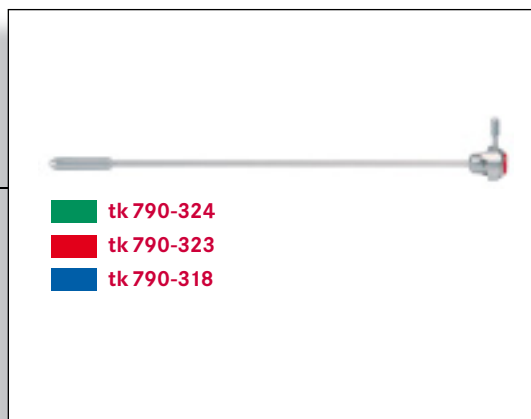
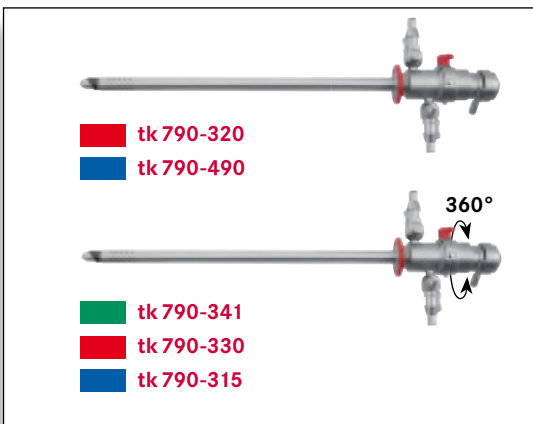

Systemübersicht
System overview

Aperçu général du système
Vista general del sistema
Visione sul sistema



Kabel
Cables
Câbles
Cables
Cavi

tk 790-310 - tk 790-313

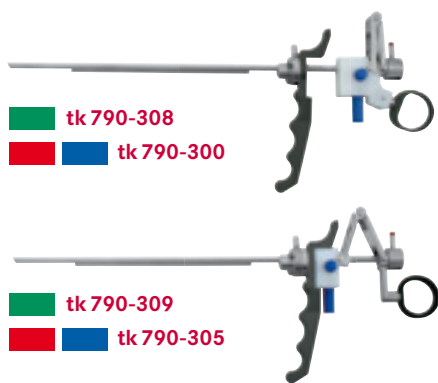

tk 790-308
tk 790-300

tk 790-309
tk 790-305



tk 700-064SF - tk 700-068SF
tk 700-074SF - tk 700-079SF

tk 700-059 - tk 700-066
tk 700-074 - tk 700-078



tk 790-498
tk 790-327
tk 790-726

tk 790-345
tk 790-727

Optiken | Optiques
 Scopes | Ópticas
 Ottiche

autoklavierbar / autoclavable
 134°C / 273°F - 18 min.

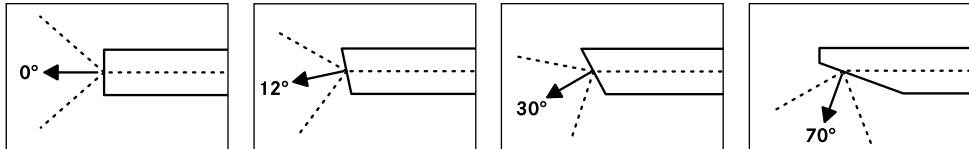

| | | | | |
|-------------------|---------------------|---------------------|---------------------|---------------------|
| Ø 2.7 mm - 302 mm | tk 700-060 | tk 700-062 | tk 700-063 | tk 700-067 |
| Ø 2.9 mm - 302 mm | tk 700-081 | tk 700-082 | tk 700-085 | - |
| Ø 4.0 mm - 302 mm | tk 700-070 | tk 700-072 | tk 700-073 | tk 700-077 |
| Ø 2.7 mm - 302 mm | tk 700-060SF | tk 700-062SF | tk 700-063SF | - |
| Ø 4.0 mm - 302 mm | tk 700-070SF | tk 700-072SF | tk 700-073SF | tk 700-077SF |

Arbeitslänge

Working length

Longueur de travail

Longitud de trabajo

Lunghezza operativa

SF = Tekno-Flex
 (see page 68)

Hochfrequenzkabel, monopolar, 3 m
High frequency cables, monopolar, 3 m

Câbles de haute fréquence, monopolaire, 3 m

Cables alta frecuencia, monopolar, 3 m

Cavi ad alta frequenza, monopolare, 3 m

| | | | | |
|--|-----------------------------------|----------|-------------------|--|
| | Aesculap, Berchtold, Martin | Ø = 4 mm | tk 790-310 | |
| | Storz, Erbe | Ø = 5 mm | tk 790-311 | |
| | Tekno, Valleylab, Bovie | Ø = 8 mm | tk 790-312 | |
| | Berchtold, Martin | Ø = 4 mm | tk 790-313 | |

Monopolare Arbeitselemente
Monopolar working elements

Eléments de travail monopolaires
Elementos de trabajo monopolares
Elementi operativi monopolari



| | | |
|-----------|---|-------------------|
| 19 Charr. |  | tk 790-308 |
| 24 Charr. |  | tk 790-300 |

Arbeitselement, passiv schneidend, einläufig
Working element, passive cutting, single stem
Elément de travail, coupe passive, single-stem
Elemento de trabajo, corte pasivo, un vástago
Elemento operativo passivo, un stelo



| | | |
|-----------|---|-------------------|
| 19 Charr. |  | tk 790-309 |
| 24 Charr. |  | tk 790-305 |

Arbeitselement, aktiv schneidend, einläufig
Working element, active cutting, single stem
Elément de travail, coupe active, single-stem
Elemento de trabajo, corte activo, un vástago
Elemento operativo attivo, un stelo



Auf Wunsch auch mit geschlossenem Griff erhältlich
Available with closed handle upon request

Disponible avec poignée fermée sur demande
Disponible con mango cerrado según de manda
Disponibile con manico chiuso su richiesta

Monopolare Elektroden
Monopolar electrodes

 Electrodes monopolaires
Electrodos monopolares
 Elettrodi monopolari

 einläufig
single stem
 single-stem
un vástago
 un stelo

Messerelektrode, gewinkelt 90°
Knife electrode, angled 90°
 Electrode à couteau, coudée 90°
Electrodo de cuchillo, angulado 90°
 Elettrodo a bisturi, angolato 90°

| 19 Charr. | 24 Charr. | 27 Charr. |
|-----------|-----------|-----------|
| | | |

| | | |
|-------------------|-------------------|-------------------|
| tk 791-420 | tk 791-350 | tk 791-450 |
|-------------------|-------------------|-------------------|

Schlingenelektrode, gerade
Loop electrode, straight
 Electrode à anse, droit
Electrodo de asa, recto
 Elettrodo ad ansa, retto

| | | |
|-------------------|-------------------|-------------------|
| tk 791-424 | tk 791-351 | tk 791-451 |
|-------------------|-------------------|-------------------|

Schlingenelektrode, gewinkelt 30°
Loop electrode, angled 30°
 Electrode à anse, coudée, 30°
Electrodo de asa, angulado 30°
 Elettrodo ad ansa, angolato 30°

| | | |
|-------------------|-------------------|-------------------|
| tk 791-421 | tk 791-352 | tk 791-452 |
|-------------------|-------------------|-------------------|

only for 0° scopes
Schlingenelektrode, gewinkelt 90°
Loop electrode, angled 90°
 Electrode à anse, coudée, 90°
Electrodo de asa, angulado 90°
 Elettrodo ad ansa, angolato 90°

| | | |
|---|-------------------|-------------------|
| - | tk 791-357 | tk 791-457 |
|---|-------------------|-------------------|

Vaporisationselektrode, gerieft, Ø 3 mm
Vaporization electrode, serrated, Ø 3 mm
 Electrode de vaporisation, striée, Ø 3 mm
Electrodo de vaporización, estriado, Ø 3 mm
 Elettrodo per vaporizzazione, scanalato, Ø 3 mm

| | | |
|---|-------------------|-------------------|
| - | tk 791-358 | tk 791-458 |
|---|-------------------|-------------------|

Vaporisationselektrode, gerieft, Ø 5 mm
Vaporization electrode, serrated, Ø 5 mm
 Electrode de vaporisation, striée, Ø 5 mm
Electrodo de vaporización, estriado, Ø 5 mm
 Elettrodo per vaporizzazione, scanalato, Ø 5 mm

| | | |
|---|-------------------|-------------------|
| - | tk 791-353 | tk 791-453 |
|---|-------------------|-------------------|

 Packung à 6 Stck.
Box of 6 pcs.
 Paquet de 6 pcs.
Paquete de 6 pzas.
 Confezione con 6 pezzi







Monopolare Elektroden
Monopolar electrodes

Electrodes monopolaires
Electrodos monopolares
Elettrodi monopolari

einläufig
single stem
single-stem
un vástago
un stelo



19 Charr. ■ 24 Charr. ■ 27 Charr. ■

| | | | | |
|---|--|------------|------------|------------|
|  | Kugelelektrode, Ø 3 mm <i>Ball electrode, Ø 3 mm</i> Electrode à boule, Ø 3 mm <i>Electrodo de bola, Ø 3 mm</i> Elettrodo a pallina, Ø 3 mm | tk 791-423 | tk 791-354 | tk 791-454 |
|  | Kugelelektrode, Ø 5 mm <i>Ball electrode, Ø 5 mm</i> Electrode à boule, Ø 5 mm <i>Electrodo de bola, Ø 5 mm</i> Elettrodo a pallina, Ø 5 mm | - | tk 791-363 | tk 791-463 |
|  | Kegelelektrode <i>Cone electrode</i> Electrode conique <i>Electrodo conico</i> Elettrodo a cono | - | tk 791-355 | tk 791-455 |
|  | Schneide/Vaporisationselektrode <i>Vaporisation electrode</i> Électrode de vaporisation <i>Electrodo de vaporización</i> Elettrodo per vaporizzazione | - | tk 791-359 | - |
|  | Rollenelektrode, glatt, Ø 3 mm <i>Roller electrode, smooth, Ø 3 mm</i> Electrode forme rouleau, lisse, Ø 3 mm <i>Electrodo de rollo, liso, Ø 3 mm</i> Elettrodo a ruolo, smusso, Ø 3 mm | tk 791-422 | tk 791-367 | tk 791-467 |
|  | Rollenelektrode, glatt, Ø 5 mm <i>Roller electrode, smooth, Ø 5 mm</i> Electrode forme rouleau, lisse, Ø 5 mm <i>Electrodo de rollo, liso, Ø 5mm</i> Elettrodo a ruolo, smusso, Ø 5 mm | - | tk 791-365 | tk 791-465 |

Packung à 6 Stck.
Box of 6 pcs.
Paquet de 6 pcs.
Paquete de 6 pzas.
Confezione con 6 pezzi

tk 790-374

Schutzhülse zur Sterilisation von Elektroden
Protection tube for sterilization of electrodes

Tube de protection et stérilisation des électrodes
Tubo protector para la esterilización de electrodos
Camicia di protezione per sterilizzazione degli elettrodi



Monopolare Schäfte
Monopolar sheaths

 Gains de travail monopolaires
Vainas de trabajo monopolares
 Camicia operativi monopolari

 drehbar
 rotatable
 rotative
 giratoria
 rotante

| ⊕ 19 / ⊕ 22 Charr. ■ | tk 790-344 | tk 790-343 | tk 790-324 |
|--|--|--|--------------------------------|
| Resektoskopschaft zur Dauerspülung <i>Resectoscope sheath for continuous flow</i> | Außenschaft <i>Outer sheath</i> | Innenschaft <i>Inner sheath</i> | Obturator <i>Obturator</i> |
| Gaine de résectoscopie à irrigation permanente <i>Vaina de resectoscopio para irrigación continua</i> | Gaine extérieur <i>Vaina exterior</i> | Gaine intérieur <i>Vaina interior</i> | Obturateur <i>Obturator</i> |
| Camicia resettoscopia a lavaggio continuo | Camicia esterna | Camicia interna | Otturatore |
| tk 790-341 | x | x | x |

 komplett
complete
 complet
completo
 completo

| ⊕ 24 / ⊕ 26 Charr. ■ | tk 790-331 | tk 790-332 | tk 790-323 |
|--|--|--|--------------------------------|
| Resektoskopschaft zur Dauerspülung <i>Resectoscope sheath for continuous flow</i> | Außenschaft <i>Outer sheath</i> | Innenschaft <i>Inner sheath</i> | Obturator <i>Obturator</i> |
| Gaine de résectoscopie à irrigation permanente <i>Vaina de resectoscopio para irrigación continua</i> | Gaine extérieur <i>Vaina exterior</i> | Gaine intérieur <i>Vaina interior</i> | Obturateur <i>Obturator</i> |
| Camicia resettoscopia a lavaggio continuo | Camicia esterna | Camicia interna | Otturatore |
| tk 790-330 | x | x | x |

 komplett
complete
 complet
completo
 completo

| ⊕ 27 / ⊕ 28,5 Charr. ■ | tk 790-316 | tk 790-317 | tk 790-318 |
|--|--|--|--------------------------------|
| Resektoskopschaft zur Dauerspülung <i>Resectoscope sheath for continuous flow</i> | Außenschaft <i>Outer sheath</i> | Innenschaft <i>Inner sheath</i> | Obturator <i>Obturator</i> |
| Gaine de résectoscopie à irrigation permanente <i>Vaina de resectoscopio para irrigación continua</i> | Gaine extérieur <i>Vaina exterior</i> | Gaine intérieur <i>Vaina interior</i> | Obturateur <i>Obturator</i> |
| Camicia resettoscopia a lavaggio continuo | Camicia esterna | Camicia interna | Otturatore |
| tk 790-315 | x | x | x |

 komplett
complete
 complet
completo
 completo

Monopolare Schäfte
Monopolar sheaths

Gaines de travail monopolaires
Vainas de trabajo monopolares
Camicia operativi monopolari



| ⊕ 24 / ⊕ 26 Charr. | tk 790-321 | tk 790-322 | tk 790-323 |
|--|--|--|--------------------------------|
| Resektoskopschaft zur Dauerspülung <i>Resectoscope sheath for continuous flow</i> | Außenschaft <i>Outer sheath</i> | Innenschaft <i>Inner sheath</i> | Obturator <i>Obturator</i> |
| Gaine de résectoscopie à irrigation permanente <i>Vaina de resectoscopia para irrigación continua</i> | Gaine extérieur <i>Vaina exterior</i> | Gaine intérieur <i>Vaina interior</i> | Obturateur <i>Obturator</i> |
| Camicia resettoscopia a lavaggio continuo | Camicia esterna | Camicia interna | Otturatore |
| tk 790-320 | x | x | x |

komplett
complete
complet
completo
completo

| ⊕ 27 / ⊕ 28,5 Charr. | tk 790-491 | tk 790-492 | tk 790-318 |
|--|--|--|--------------------------------|
| Resektoskopschaft zur Dauerspülung <i>Resectoscope sheath for continuous flow</i> | Außenschaft <i>Outer sheath</i> | Innenschaft <i>Inner sheath</i> | Obturator <i>Obturator</i> |
| Gaine de résectoscopie à irrigation permanente <i>Vaina de resectoscopia para irrigación continua</i> | Gaine extérieur <i>Vaina exterior</i> | Gaine intérieur <i>Vaina interior</i> | Obturateur <i>Obturator</i> |
| Camicia resettoscopia a lavaggio continuo | Camicia esterna | Camicia interna | Otturatore |
| tk 790-490 | x | x | x |

komplett
complete
complet
completo
completo

Obturatoren
Obturator

Obturateurs
Obturadores
Otturatori

| | | |
|-----------|---|-------------------|
| 19 Charr. |  | tk 790-324 |
| 24 Charr. |  | tk 790-323 |
| 27 Charr. |  | tk 790-318 |



Standardobturator
Standard obturator

Obturateur standard
Obturador estándar
Otturatore standard

| | | |
|-----------|---|-------------------|
| 19 Charr. |  | tk 790-498 |
| 24 Charr. |  | tk 790-327 |
| 27 Charr. |  | tk 790-726 |

Sichtobturator für Dauerspülung
Visual obturator for continuous flow

Obturateur visuel pour irrigation permanente
Obturador óptico para irrigación continua
Otturatore ottico per lavaggio continuo

| | | | |
|-----------|---|------------|-------------------|
| 24 Charr. |  | Ø 5 Charr. | tk 790-345 |
| 27 Charr. |  | Ø 7 Charr. | tk 790-727 |

Sichtobturator
Visual obturator

Obturateur visuel
Obturador óptico
Otturatore ottico

Instrumentenkanal
instrument channel

canal d'instruments
canal para instrumentos
canale per strumenti



ENDOSKOPIE GERÄTE

ENDOSCOPIC UNITS

Systemübersicht
System overview

Aperçu général du système
Vista general del sistema
Visione sul sistema

BIPOLARK

| | |
|------------------------|---|
| ⊙ 17.5 / ⊙ 18.5 Charr. | ■ |
| ⊙ 19 / ⊙ 22 Charr. | ■ |
| ⊙ 24 / ⊙ 26 Charr. | ■ |

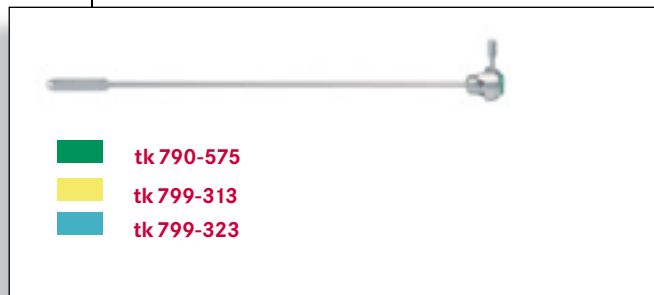
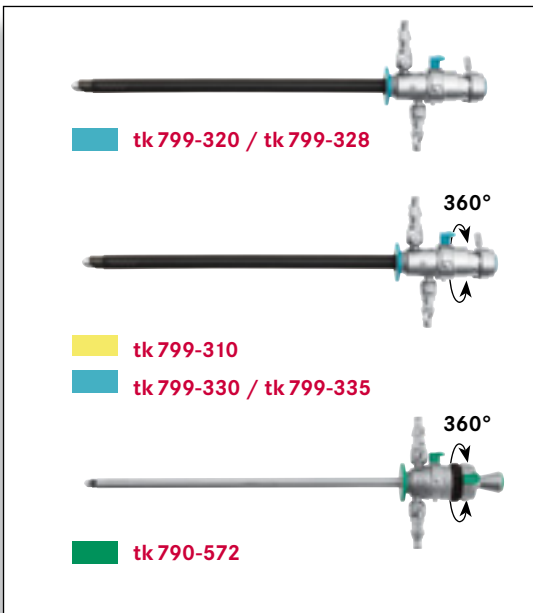
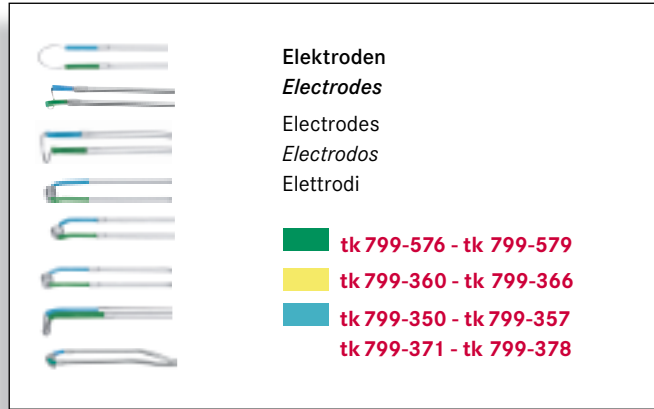

Permanente Spülung
Continuous flow

Irrigation permanente
Irrigación continua
Flusso continuo

Systemübersicht
System overview

Aperçu général du système
Vista general del sistema
Visione sul sistema

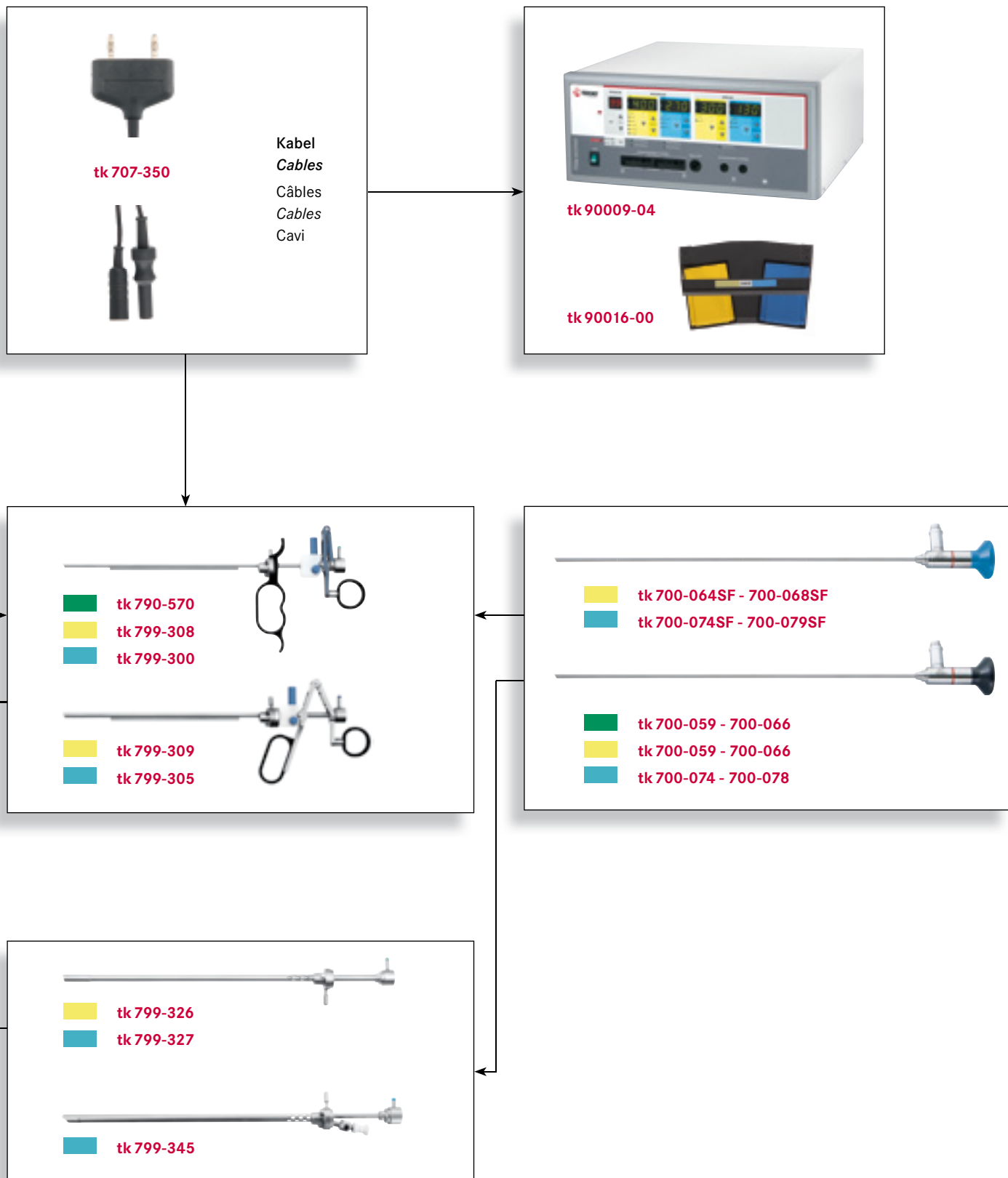

Optiken | Optiques
 Scopes | Ópticas
 Ottiche

autoklavierbar / autoclavable
 134°C / 273°F - 18 min.

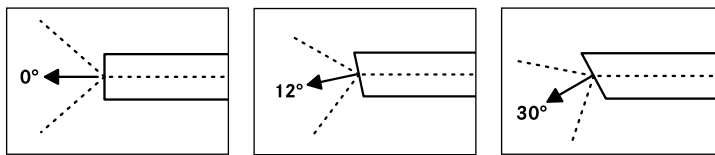

| | | | |
|-------------------|---------------------|---------------------|---------------------|
| Ø 2.9 mm - 302 mm | tk 700-081 | tk 700-082 | tk 700-085 |
| Ø 4.0 mm - 302 mm | tk 700-070 | tk 700-072 | tk 700-073 |
| Ø 4.0 mm - 302 mm | tk 700-070SF | tk 700-072SF | tk 700-073SF |

Arbeitslänge
 Working length

Longueur de travail
 Longitud de trabajo
 Lunghezza operativa

SF = Tekno-Flex
 (see page 68)

Bipolare Arbeitselemente
Bipolar working elements

Eléments de travail bipolaires
Elementos de trabajo bipolares
Elementi operativi bipolari

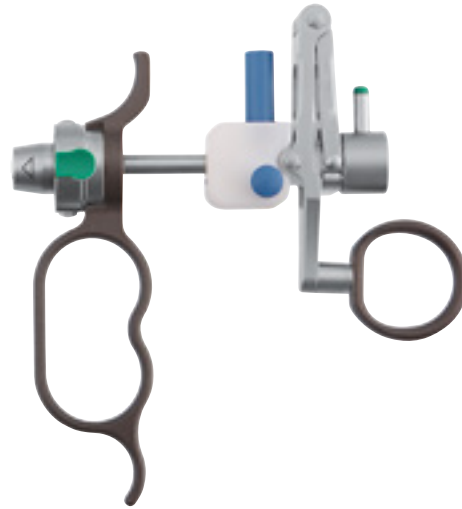



18.5 Charr.  **tk 790-570**

Arbeitselement, passiv schneidend, einläufig
Working element, passive cutting, single stem

Elément de travail, coupe passive, single-stem
Elemento de trabajo, corte pasivo, un vástago
Elemento operativo passivo, un stelo



| | 18.5 Charr.  | |
|---|--|-------------------|
|  Schlingenelektrode, gewinkelt 30° <i>Loop electrode, angled 30°</i> Electrode à anse, coudée, 30° <i>Electrodo de asa, angulado 30°</i> Elettrodo ad ansa, angolato 30° | 30° | tk 799-576 |
|  Messerelektrode, gewinkelt 90° <i>Knife electrode, angled 90°</i> Electrode à couteau, coudée 90° <i>Electrodo de cuchillo, angulado 90°</i> Elettrodo a bisturi, angolato 90° | 30° | tk 799-577 |
|  Rollenelektrode, glatt, Ø 2 mm <i>Roller electrode, smooth, Ø 2 mm</i> Electrode forme rouleau, lisse, Ø 2 mm <i>Electrodo de rollo, liso, Ø 2 mm</i> Elettrodo a ruolo, smusso, Ø 2 mm | 30° | tk 799-578 |
|  Kugelelektrode, Ø 2 mm <i>Ball electrode, Ø 2 mm</i> Electrode à boule, Ø 2 mm <i>Electrodo de bola, Ø 2 mm</i> Elettrodo a pallina, Ø 2 mm | 30° | tk 799-579 |

Packung á 6 Stück
Box of 6 pieces
Paquet de 6 pcs.
Paquete de 6 pzas.
Confezione con 6 pezzi

für Optiken
for scopes
pour optiques
para ópticas
per ottiche

Bipolare Resektoskopschäfte
Bipolar resectoscope sheaths

Gaines de résectoscopie bipolaire
Vainas de resectoscopia bipolares
Camicie per resettoscopio bipolari

BIPOLAR 



| ☉ 17,5 / ☉ 18.5 Charr.  | tk 790-573 | tk 790-574 | tk 790-575 |
|--|--|--|--------------------------------|
| Resektoskopschaft zur Dauerspülung <i>Resectoscope sheath for continuous flow</i> | Außenschaft <i>Outer sheath</i> | Innenschaft <i>Inner sheath</i> | Obturator <i>Obturator</i> |
| Gaine de résectoscopie à irrigation permanente <i>Vaina de resectoscopio para irrigación continua</i> | Gaine extérieur <i>Vaina exterior</i> | Gaine intérieur <i>Vaina interior</i> | Obturateur <i>Obturador</i> |
| Camicia resettoscopia a lavaggio continuo | Camicia esterna | Camicia interna | Otturatore |
| tk 790-572 | x | x | x |
| komplett <i>complete</i> | | | |
| complet <i>completo</i> | | | |
| completo | | | |

Bipolare Arbeitselemente
Bipolar working elements

Eléments de travail bipolaires
Elementos de trabajo bipolares
Elementi operativi bipolari



| | | |
|-----------|---|------------|
| 19 Charr. |  | tk 799-308 |
| 24 Charr. |  | tk 799-300 |

passiv schneidend, einläufig
passive cutting, single stem
oupe passive, single-stem
corte pasivo, un vástago
passivo, un stelo



| | | |
|-----------|---|------------|
| 19 Charr. |  | tk 799-309 |
| 24 Charr. |  | tk 799-305 |

aktiv schneidend, einläufig
active cutting, single stem
coupe active, single-stem
corte activo, un vástago
operativo attivo, un stelo





| | | |
|---|------------|---|
| TEKNO TOM 411 PRO, 500 | tk 707-350 | 5 m |
| Geräteseite Unit side Coté appareil Lado equipo Lato elettrobisturi | | Instrumentenseite Instrument side Coté instrument Lado instrumento Lato strumento |



Bipolare Elektroden
Bipolar electrodes

 Electrodes bipolaires
Electrodos bipolares
 Elettrodi bipolari

BIPOLAR

| | | | 19 Charr.  | 24 Charr.  | 24 Charr.  |
|---|----------|----------|--|--|---|
| | | | Packung à 6 Stck. Box of 6 pcs. | | Packung à 10 Stck. Box of 10 pcs. |
| Schlinge, gerade 0° <i>Loop, straight 0°</i> Anse, droite 0° <i>Asa, recta 0°</i> Ansa, retta 0° | 0° / 12° | 0° / 30° | tk 799-361 | tk 799-351 | - |
| Schlinge, 30°, fein <i>Loop, 30°, thin</i> Anse, 30°, fine <i>Asa, 30°, fina</i> Ansa, 30°, fina | 30° | 30° | tk 799-362 | tk 799-352 | - |
| Schlinge, 30°, stark <i>Loop, 30°, thick</i> Anse, 30°, forte <i>Asa, 30°, fuerte</i> Ansa, 30°, forte | 30° | 30° | - | tk 799-372 | tk 799-372S |
| PI-Schlinge, 30°, extra langlebig <i>PI-Loop, 30°, extra longlasting</i> PI-anse, 30°, extra durable <i>PI-asa, 30°, extra duradero</i> PI-ansa, 30°, extra durevole | 30° | 30° | - | tk 799-374 | - |
| PI-Schlinge, 90°, extra langlebig <i>PI-Loop, 90°, extra longlasting</i> PI-anse, 90°, extra durable <i>PI-asa, 90°, extra duradero</i> PI-ansa, 90°, extra durevole | 0° / 12° | 0° | - | tk 799-378 | - |
| Schlinge, 90°, fein <i>Loop, 90°, thin</i> Anse, 90°, fine <i>Asa, 90°, fina</i> Ansa, 90°, fina | 0° / 12° | 0° | - | tk 799-353 | - |
| Schlinge, 90°, stark <i>Loop, 90°, thick</i> Anse, 90°, forte <i>Asa, 90°, fuerte</i> Ansa, 90°, forte | 0° / 12° | 0° | - | tk 799-373 | tk 799-373S |

 für Optiken
for scopes

 pour optique
para óptica
 per ottica

 für Schäfte
for sheaths

 pour gaines
para vainas
 per camicie

 wiederverwendbar
reusable

 réutilisable
reutilizable
 rintilizzabile

 steril
sterile

 stérile
estéril
 sterile

Bipolare Elektroden | Electrodes bipolaires
 Bipolar electrodes | Electrodoos bipolares
 Elettrodi bipolari



| | | |
|---|------------|--------|
| Vaporisationselektrode, gerieft, Ø 3 mm Vaporization electrode, serrated, Ø 3 mm Electrode à vaporisation, striée, Ø 3 mm Electrodo de vaporización, estriado, Ø 3 mm Elettrodo per vaporizzazione, scanalato, Ø 3 mm | 0°/12°/30° | 0°/30° |
|---|------------|--------|

| | | |
|------------------------------------|---------------|--------------------------------------|
| 19 Charr. | 24 Charr. | 24 Charr. |
| Packung à 6 Stck. Box of 6 pcs. | | Packung à 10 Stck. Box of 10 pcs. |



| | | |
|---|------------|--------|
| Kugel, Ø 3 mm Ball, Ø 3 mm Boule, Ø 3 mm Bola, Ø 3 mm Pallina, Ø 3 mm | 0°/12°/30° | 0°/30° |
|---|------------|--------|

| | | |
|---|------------|---|
| - | tk 799-354 | - |
|---|------------|---|



| | | |
|--|------------|--------|
| Rolle, glatt, Ø 3 mm Roller, smooth, Ø 3 mm Rouleau, lisse, Ø 3 mm Rollo, liso, Ø 3 mm Ruolo, smusso, Ø 3 mm | 0°/12°/30° | 0°/30° |
|--|------------|--------|

| | | |
|------------|------------|-------------|
| tk 799-365 | tk 799-355 | tk 799-355S |
|------------|------------|-------------|



| | | |
|--|------------|--------|
| Messer, 90° Knife, 90° Couteau, 90° Cuchillo, 90° Bisturi, 90° | 0°/12°/30° | 0°/30° |
|--|------------|--------|

| | | |
|------------|------------|---|
| tk 799-366 | tk 799-356 | - |
|------------|------------|---|



| | | |
|---------------------------------------|------------|--------|
| Kegel Cone Coñe Cono Cono | 0°/12°/30° | 0°/30° |
|---------------------------------------|------------|--------|

| | | |
|------------|------------|-------------|
| tk 799-360 | tk 799-350 | tk 799-350S |
|------------|------------|-------------|



| | | |
|---|------------|--------|
| Pilz Mushroom Champignon Seta Fungo | 0°/12°/30° | 0°/30° |
|---|------------|--------|

| | | |
|---|------------|---|
| - | tk 799-357 | - |
|---|------------|---|

| | | |
|---|------------|---|
| - | tk 799-367 | - |
|---|------------|---|

| | | | |
|--|---|---|--|
| für Optiken for scopes pour optique para óptica per ottica | für Schäfte for sheaths pour gaines para vainas per camicie | wiederverwendbar reusable réutilisable reutilizable rutilizzabile | steril sterile stérile estéril sterile |
|--|---|---|--|

Bipolare Resektoskopschäfte
Bipolar resectoscope sheaths

 Gainses de résectoscopie bipolaire
Vainas de resectoscopia bipolares
 Camicie per resettoscopio bipolari

BIPOLAR

 drehbar
 rotatable
 rotative
 giratoria
 rotante

| ⊕ 19 / ⊕ 22 Charr. | tk 799-311 | tk 799-312 | tk 799-313 |
|---|--|--|--------------------------------|
| Resektoskopschaft zur Dauerspülung <i>Resectoscope sheath for continuous flow</i> | Außenschaft <i>Outer sheath</i> | Innenschaft 30° <i>Inner sheath 30°</i> | Obturator <i>Obturator</i> |
| Gaine de résectoscopie à irrigation permanente <i>Vaina de resectoscopio para irrigación continua</i> | Gaine extérieur <i>Vaina exterior</i> | Gaine intérieur 30° <i>Vaina interior 30°</i> | Obturateur <i>Obturator</i> |
| Camicia resettoscopica a lavaggio continuo | Camicia esterna | Camicia interna 30° | Otturatore |
| tk 799-310 | x | x | x |

 komplett
complete
 complet
completo
 completo

| ⊕ 24 / ⊕ 26 Charr. | tk 799-331 | tk 799-332 | tk 799-333 | tk 799-323 |
|---|--|--|--|--------------------------------|
| Resektoskopschaft zur Dauerspülung <i>Resectoscope sheath for continuous flow</i> | Außenschaft <i>Outer sheath</i> | Innenschaft 30° <i>Inner sheath 30°</i> | Innenschaft 0° <i>Inner sheath 0°</i> | Obturator <i>Obturator</i> |
| Gaine de résectoscopie à irrigation permanente <i>Vaina de resectoscopio para irrigación continua</i> | Gaine extérieur <i>Vaina exterior</i> | Gaine intérieur 30° <i>Vaina interior 30°</i> | Gaine intérieur 0° <i>Vaina interior 0°</i> | Obturateur <i>Obturator</i> |
| Camicia resettoscopica a lavaggio continuo | Camicia esterna | Camicia interna 30° | Camicia interna 0° | Otturatore |
| tk 799-330 | x | x | - | x |
| tk 799-335 | x | - | x | x |

 komplett
complete
 complet
completo
 completo

Bipolare Resektoskopschäfte
Bipolar resectoscope sheaths

Gaines de résectoscopie bipolaire
Vainas de resectoscopia bipolares
Camicie per resettoscopio bipolari



| ⊕ 24 / ⊕ 26 Charr. | tk 799-321 | tk 799-322 | tk 799-324 | tk 799-323 |
|--|--|--|--|--------------------------------|
| Resektoskopschaft zur Dauerspülung <i>Resectoscope sheath for continuous flow</i> | Außenschaft <i>Outer sheath</i> | Innenschaft 30° <i>Inner sheath 30°</i> | Innenschaft 0° <i>Inner sheath 0°</i> | Obturator <i>Obturator</i> |
| Gaine de résectoscopie à irrigation permanente <i>Vaina de resectoscopio para irrigación continua</i> | Gaine extérieur <i>Vaina exterior</i> | Gaine intérieur 30° <i>Vaina interior 30°</i> | Gaine intérieur 0° <i>Vaina interior 0°</i> | Obturateur <i>Obturator</i> |
| Camicia resettoscopia a lavaggio continuo | Camicia esterna | Camicia interna 30° | Camicia interna 0° | Otturatore |
| tk 799-320 | x | x | - | x |
| tk 799-328 | x | - | x | x |

komplett
complete
complet
completo
completo

Obturatoren
Obturator

Obturateur
Obturadores
Otturatori

BIPOLARK



| | | |
|-----------|---|-------------------|
| 19 Charr. |  | tk 799-313 |
| 24 Charr. |  | tk 799-323 |

Standardobturator
Standard obturator

Obturateur standard
Obturator estándar
Otturatore standard



| | | |
|-----------|---|-------------------|
| 19 Charr. |  | tk 799-326 |
| 24 Charr. |  | tk 799-327 |

Sichtobturator für Dauerspülung
Visual obturator for continuous flow

Obturateur visuel pour irrigation permanente
Obturator óptico para irrigación continua
Otturatore ottico per lavaggio continuo



| | | | |
|-----------|---|------------|-------------------|
| 24 Charr. |  | Ø 5 Charr. | tk 799-345 |
|-----------|---|------------|-------------------|

Sichtobturator
Visual obturator
Obturateur visuel
Obturator óptico
Otturatore ottico

Instrumentenkanal
instrument channel
canal d'instruments
canal para instrumentos
canale per strumenti

OP - Laparoscope | **OP - Laparoscopes**
OP - Laparoscopes | **OP - Laparoscopios**
 Laparoscopi operativi

OP - Laparoskop mit integriertem Instrumentenkanal, 0° Weitwinkel, Paralleleinblick
OP - Laparoscope with integrated instrument channel, 0° wide angle, parallel view

OP - Laparoscope avec canal d'instruments incorporé, 0° grand angle, vision parallèle
OP - Laparoscopio con canal incorporado para instrumentos, 0° gran ángulo, vista paralela
 Laparoscopi operativo con canale di lavoro, 0° grandangolo, vista parallela

autoklavierbar / autoclavable
 134°C / 273°F - 18 min.

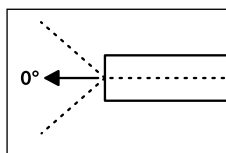
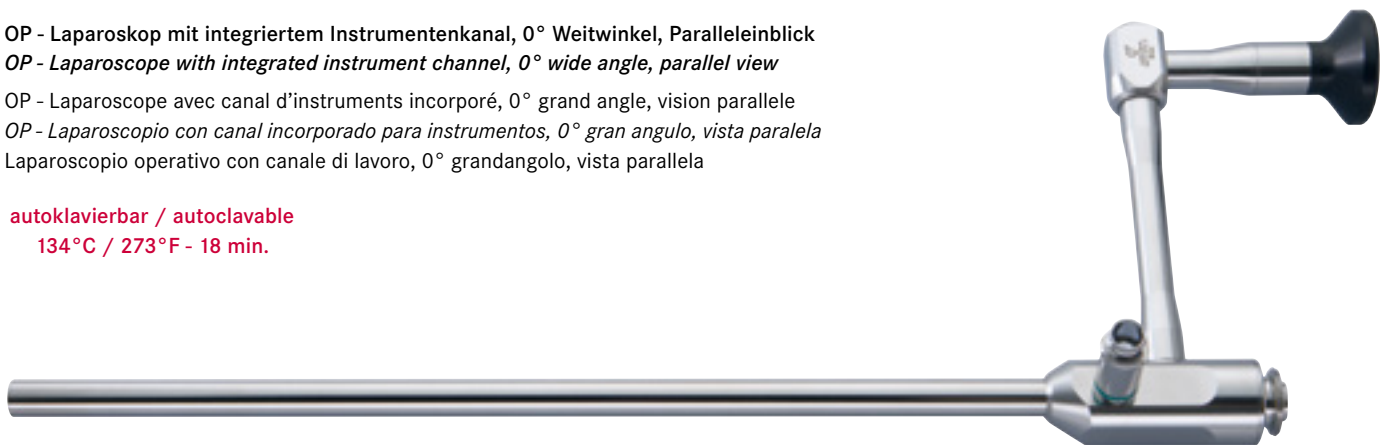

| | | |
|---|--|---|
| Ø 10.0 mm - 268 mm | Ø 6.0 mm | tk 700-250 |
| Arbeitslänge <i>Working length</i> | Instrumentenkanal <i>Instrument channel</i> | inkl. Adapter <i>incl. adapter</i> |
| Longueur de travail <i>Longitud de trabajo</i> | Canal d'instrument <i>Canal para instrumentos</i> | incl. adaptateur <i>Adaptador incluido</i> |
| Lunghezza operativa | canale operativo | Adattore incluso |

| |
|--------------------------------|
| tk 700-255 |
| Adapter <i>Adapter</i> |
| Adaptateur <i>Adaptador</i> |
| Adattore |

OP - Laparoskop mit integriertem Instrumentenkanal, 0° Weitwinkel, Lateraleinblick
OP - Laparoscope with integrated instrument channel, 0° wide angle, lateral view

OP - Laparoscope avec canal d'instruments incorporé, 0° grand angle, vision latéral
OP - Laparoscopio con canal incorporado para instrumentos, 0° gran ángulo, vista lateral
 Laparoscopi operativo con canale di lavoro, 0° grandangolo, vista laterale

autoklavierbar / autoclavable
 134°C / 273°F - 18 min.

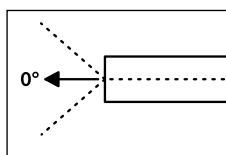
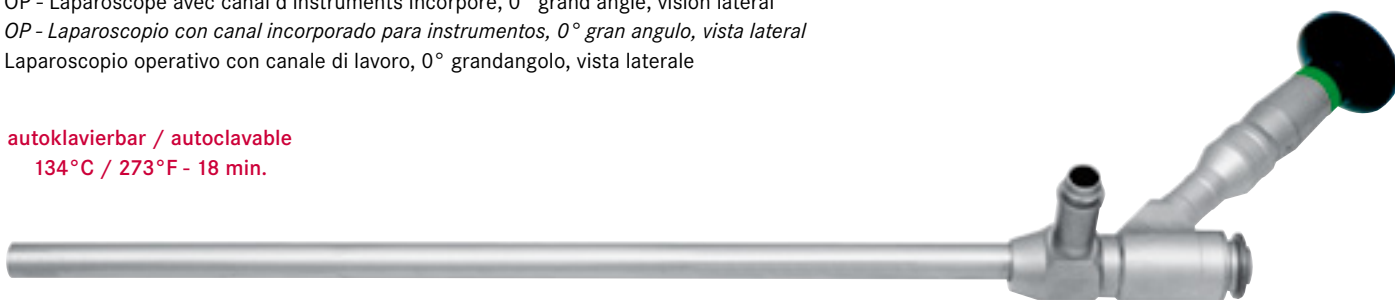

| | | |
|---|--|---|
| Ø 10.0 mm - 268 mm | Ø 6.0 mm | tk 700-251 |
| Arbeitslänge <i>Working length</i> | Instrumentenkanal <i>Instrument channel</i> | inkl. Adapter <i>incl. adapter</i> |
| Longueur de travail <i>Longitud de trabajo</i> | Canal d'instrument <i>Canal para instrumentos</i> | incl. adaptateur <i>Adaptador incluido</i> |
| Lunghezza operativa | Canale operativo | Adattore incluso |

| |
|--------------------------------|
| tk 700-256 |
| Adapter <i>Adapter</i> |
| Adaptateur <i>Adaptador</i> |
| Adattore |

Ring Applikatoren
Ring applicators

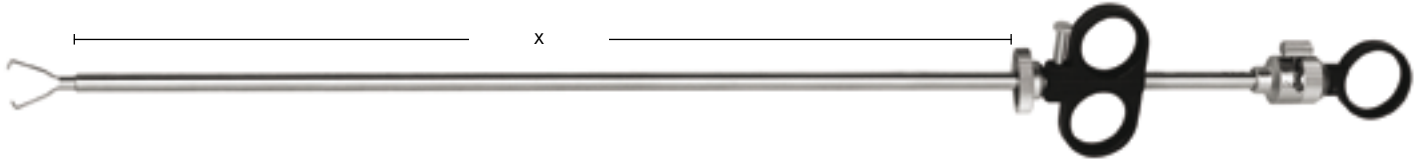
 Appicateurs des anneaux
 Aplicadores de anillos
 Applicatore per anelli

| | |
|--------------------|-------------------|
| | x = 327 mm |
| Ø 6 mm - 18 Charr. | tk 791-180 |

Zur Anwendung mit OP-Laparoskop tk 700-250.
 Für einen Einstich; komplett mit Ladevorrichtung und Konusteil.
For use with OP-Laparoscope tk 700-250.
For single puncture; complete with loading device and cone part.
 Pour l'utilisation avec laparoscope tk 700-250.
 Pour une ponction; complet avec chargeur et conus.
Para la utilización con laparoscop tk 700-250.
Para una punción; completo con cargador y punta conica.
 Per utilizzo con laparoscopia operativo tk 700-250.
 Per una incisione; completo di strumenti di carica e parte a cono.

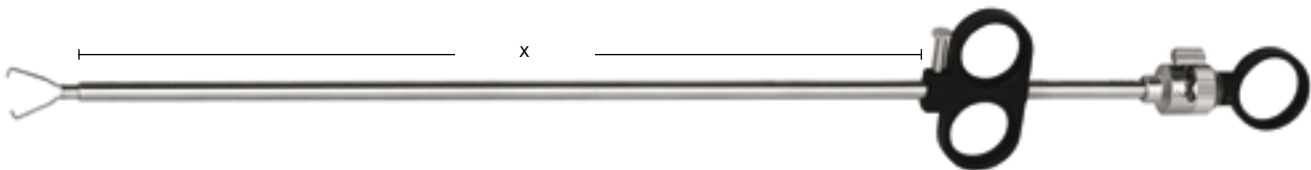

| | |
|----------------------|-------------------|
| | x = 287 mm |
| Ø 6.5 mm - 20 Charr. | tk 791-185 |

Zur Anwendung mit einer regulären Trokarhülle (7 mm).
 Für den zweiten Einstich; komplett mit Ladevorrichtung und Konusteil.
For use with a regular trocar sheath (7 mm).
For second puncture; complete with loading device and cone part.
 Pour l'utilisation avec un trocar standard (7 mm).
 Pour la deuxième ponction; complet avec chargeur et conus.
Para la utilización con un trocar estandard (7 mm).
Para segundo punción, completo con cargador y punta conica.
 Per utilizzo con trocar normale (7 mm).
 Per due incisioni; completo di strumenti di carica e parte a cono.

tk 791-187

Konusteil für tk 791-180 / tk 791-185
Cone part for tk 791-180 / tk 791-185
 Conus pour tk 791-180 / tk 791-185
Punta conica para tk 791-180 / tk 791-185
 Parte conica per tk 791-180 / tk 791-185

tk 791-189

Ladevorrichtung für tk 791-180 / tk 791-185
Loading device for tk 791-180 / tk 791-185
 Chargeur pour tk 791-180 / tk 791-185
Cargador para tk 791-180 / tk 791-185
 Caricatore per tk 791-180 / tk 791-185

Uterusmanipulator
Uterus manipulator

Manipulator utérin
Manipulador uterino
Manipolatore uterino



| | | | | | | |
|-------------------|-------------------|-------------------|-------------------|-------------------|-------------------|-------------------|
| | Ø 3.0 x 45 mm | Ø 3.0 x 55 mm | Ø 3.2 x 34 mm | Ø 3.2 x 45 mm | Ø 8.0 x 80 mm | Ø 10.0 x 100 mm |
| tk 791-151 | tk 791-152 | tk 791-153 | tk 791-154 | tk 791-155 | tk 791-156 | tk 791-157 |

Manipulator
Manipulator
Manipulator
Manipulador
Manipolatore
Adaptateur
Adaptador
Adattore

| | | | | | | |
|-------------------|----------|----------|----------|----------|----------|----------|
| tk 791-150 | x | x | x | x | x | x |
|-------------------|----------|----------|----------|----------|----------|----------|

komplett
complete
complet
completo
completo

Instrumente
Instrumentos
Instruments
Instrumentos
Strumenti
Myombohrer
Myoma drill

Mèche pour myomes

Taladro para miomas

Fissatore per mioma



| | | |
|----------|-------------------|-------------------|
| | x = 330 mm | x = 420 mm |
| Ø 5.0 mm | tk 791-170 | tk 791-176 |

Arbeitslänge
Working length

Longueur de travail

Longitud de trabajo

Lunghezza operativa



| | | |
|-----------|-------------------|-------------------|
| | x = 330 mm | x = 420 mm |
| Ø 10.0 mm | tk 791-174 | tk 791-175 |

Arbeitslänge
Working length

Longueur de travail

Longitud de trabajo

Lunghezza operativa

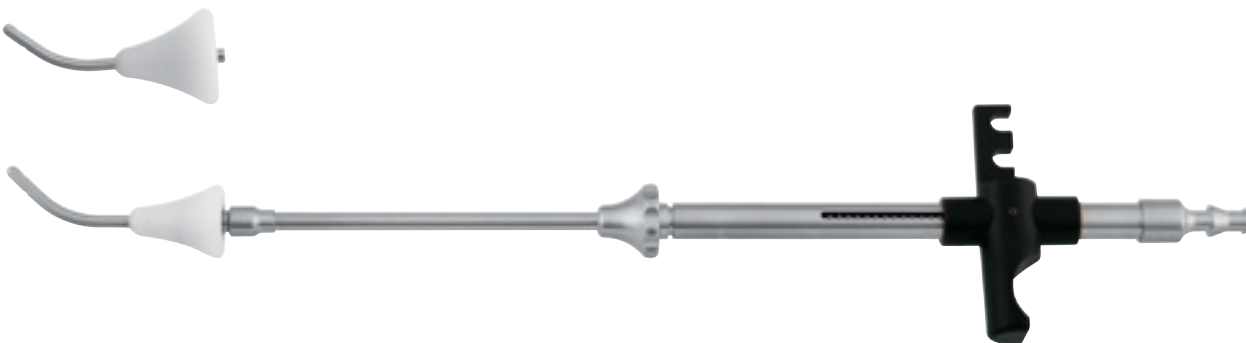
COHEN
tk 791-161
Intra-Uterin-Sonde mit 1 kleinen und 1 großen Portio-Kegelansatz
Intra-uterine probe with 1 small and 1 large cervical cone

Sonde intra utérin avec 1 petit et 1 grand adaptateur conique

Sonda intra-uterina con 1 pequeño y 1 grande adaptador conico

Sonda intra-uterina con un cono cervicale piccolo ed uno grande

Uterussonden
Uterus probes

Sondes utérinaires
Sondas para el útero
Sondas uterinas



VALLEIX

250 mm - 9¾" tk 34197-25

graduiert, mit Schieber
graduated, with slider
gradué, avec curseur
graduado, con cursor
graduato, con cursore



MARTIN

320 mm - 12½" tk 34198-32 tk 34199-32

| | | |
|------------------|---------------|------------------|
| graduiert | fest | biegsam |
| <i>graduated</i> | <i>rigid</i> | <i>malleable</i> |
| gradué | rigide | malléable |
| <i>graduado</i> | <i>rigido</i> | <i>maleable</i> |
| graduato | rigido | malleabile |



SIMS

320 mm - 12½" tk 34200-32 tk 34201-32

| | | |
|------------------|---------------|------------------|
| graduiert | fest | biegsam |
| <i>graduated</i> | <i>rigid</i> | <i>malleable</i> |
| gradué | rigide | malléable |
| <i>graduado</i> | <i>rigido</i> | <i>maleable</i> |
| graduato | rigido | malleabile |

Metallkatheter
Metal catheter

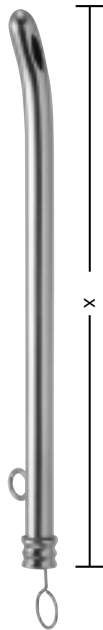
 Cathéters métalliques
 Catéteres metalicos
 Cateteri di metallo

GUYON

| | | x = 150 mm |
|----------------------|---------------|--------------------|
| Ø 2 mm | 6 Charr./Fr. | tk 30410-06 |
| Ø 2 $\frac{1}{3}$ mm | 7 Charr./Fr. | tk 30410-07 |
| Ø 2 $\frac{2}{3}$ mm | 8 Charr./Fr. | tk 30410-08 |
| Ø 3 mm | 9 Charr./Fr. | tk 30410-09 |
| Ø 3 $\frac{1}{3}$ mm | 10 Charr./Fr. | tk 30410-10 |
| Ø 3 $\frac{2}{3}$ mm | 11 Charr./Fr. | tk 30410-11 |
| Ø 4 mm | 12 Charr./Fr. | tk 30410-12 |
| Ø 4 $\frac{1}{3}$ mm | 13 Charr./Fr. | tk 30410-13 |
| Ø 4 $\frac{2}{3}$ mm | 14 Charr./Fr. | tk 30410-14 |
| Ø 5 mm | 15 Charr./Fr. | tk 30410-15 |
| Ø 5 $\frac{1}{3}$ mm | 16 Charr./Fr. | tk 30410-16 |
| Ø 5 $\frac{2}{3}$ mm | 17 Charr./Fr. | tk 30410-17 |
| Ø 6 mm | 18 Charr./Fr. | tk 30410-18 |
| Ø 6 $\frac{1}{3}$ mm | 19 Charr./Fr. | tk 30410-19 |
| Ø 6 $\frac{2}{3}$ mm | 20 Charr./Fr. | tk 30410-20 |
| Ø 7 mm | 21 Charr./Fr. | tk 30410-21 |
| Ø 7 $\frac{1}{3}$ mm | 22 Charr./Fr. | tk 30410-22 |
| Ø 7 $\frac{2}{3}$ mm | 23 Charr./Fr. | tk 30410-23 |
| Ø 8 mm | 24 Charr./Fr. | tk 30410-24 |

Uterus-Dilatatoren
Uterine dilators

Dilateurs du col de l'utérus
Dilatadores uterinos
Dilatatori uterini



HEGAR

| | |
|----------|--------------------|
| Ø 1.0 mm | tk 34250-10 |
| Ø 1.5 mm | tk 34250-15 |
| Ø 2.0 mm | tk 34250-20 |
| Ø 2.5 mm | tk 34250-25 |
| Ø 3.0 mm | tk 34250-30 |
| Ø 3.5 mm | tk 34250-35 |
| Ø 4.0 mm | tk 34250-40 |
| Ø 4.5 mm | tk 34250-45 |
| Ø 5.0 mm | tk 34250-50 |
| Ø 5.5 mm | tk 34250-55 |
| Ø 6.0 mm | tk 34250-60 |
| Ø 6.5 mm | tk 34250-65 |
| Ø 7.0 mm | tk 34250-70 |
| Ø 7.5 mm | tk 34250-75 |
| Ø 8.0 mm | tk 34250-80 |
| Ø 8.5 mm | tk 34250-85 |
| Ø 9.0 mm | tk 34250-90 |
| Ø 9.5 mm | tk 34250-95 |

| | |
|-----------|--------------------|
| Ø 10.0 mm | tk 34251-00 |
| Ø 10.5 mm | tk 34251-05 |
| Ø 11.0 mm | tk 34251-10 |
| Ø 11.5 mm | tk 34251-15 |
| Ø 12.0 mm | tk 34251-20 |
| Ø 12.5 mm | tk 34251-25 |
| Ø 13.0 mm | tk 34251-30 |
| Ø 13.5 mm | tk 34251-35 |
| Ø 14.0 mm | tk 34251-40 |
| Ø 14.5 mm | tk 34251-45 |
| Ø 15.0 mm | tk 34251-50 |
| Ø 15.5 mm | tk 34251-55 |
| Ø 16.0 mm | tk 34251-60 |
| Ø 16.5 mm | tk 34251-65 |
| Ø 17.0 mm | tk 34251-70 |
| Ø 17.5 mm | tk 34251-75 |
| Ø 18.0 mm | tk 34251-80 |
| Ø 18.5 mm | tk 34251-85 |

| | |
|-----------|--------------------|
| Ø 19.0 mm | tk 34251-90 |
| Ø 19.5 mm | tk 34251-95 |
| Ø 20.0 mm | tk 34252-00 |
| Ø 21.0 mm | tk 34252-10 |
| Ø 22.0 mm | tk 34252-20 |
| Ø 23.0 mm | tk 34252-30 |
| Ø 24.0 mm | tk 34252-40 |
| Ø 25.0 mm | tk 34252-50 |
| Ø 26.0 mm | tk 34252-60 |
| Ø 27.0 mm | tk 34252-70 |
| Ø 28.0 mm | tk 34252-80 |
| Ø 29.0 mm | tk 34252-90 |
| Ø 30.0 mm | tk 34253-00 |

HEGAR

| | | |
|----------------|----|--------------------|
| Ø 4 mm - 17 mm | 14 | tk 34260-14 |
| Ø 1 mm - 26 mm | 26 | tk 34260-26 |

Stück per Satz Satz, ohne Metalletui
Pieces per set Set, without metal case

Pièces per jeu Jeu, sans boîte en métal
Piezas para juego Juego, sin caja de metal

Pezzi per serie Serie, senza astuccio metallico



| | |
|----------------|--------------------|
| | 240 x 240 x 50 mm |
| Ø 1 mm - 14 mm | tk 34261-28 |

Siebkorb für 26 Hegarstifte
Wire basket for 26 Hegar dilators

Panier pour 26 dilateurs Hegar
Cesta oara 26 dilatadores Hegar

Castello per 26 dilatatori Hegar

Uterus-Dilatatoren
Uterine dilators

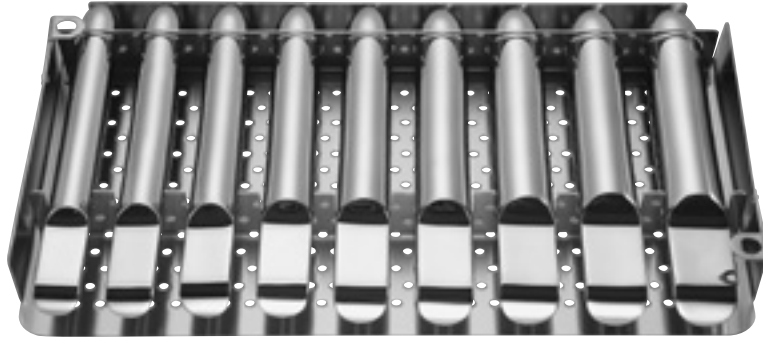
Dilateurs du col de l'utérus
Dilatadores uterinos
Dilatatori uterini

HEGAR

| | | |
|----------------|----|--------------------|
| Ø 4 mm - 17 mm | 14 | tk 34261-14 |
| Ø 1 mm - 26 mm | 26 | tk 34261-26 |

| | |
|--------------------------|--------------------------------|
| Stück per Satz | Satz, in Metalletui |
| <i>Pieces per set</i> | <i>Set, in metal case</i> |
| Pièces per jeu | Jeu, en boîte de métal |
| <i>Piezas para juego</i> | <i>Juego, en caja de metal</i> |
| Pezzi per serie | Serie, con astuccio metallico |

tk 34261-27
Metalletui, allein für Dilatatoren Set tk 34261-26
Metal case alone, for dilator set tk 34261-26

Boîte en métal seule, pour jeu de dilateurs tk 34261-26
Caja de metal sola, para juego de dilatadores tk 34261-26
Astuccio metallico solo, per set dilatatori tk 34261-26

Uterus-Dilatatoren
Uterine dilators

Dilateurs du col de l'utérus
Dilatadores uterinos
Dilatatori uterini



HEGAR

| | |
|--------------|--------------------|
| Ø 1 / 2 mm | tk 34262-02 |
| Ø 3 / 4 mm | tk 34262-04 |
| Ø 5 / 6 mm | tk 34262-06 |
| Ø 7 / 8 mm | tk 34262-08 |
| Ø 9 / 10 mm | tk 34262-10 |
| Ø 11 / 12 mm | tk 34262-12 |
| Ø 13 / 14 mm | tk 34262-14 |
| Ø 15 / 16 mm | tk 34262-16 |
| Ø 17 / 18 mm | tk 34262-18 |
| Ø 19 / 20 mm | tk 34262-20 |
| Ø 21 / 22 mm | tk 34262-22 |
| Ø 23 / 24 mm | tk 34262-24 |
| Ø 25 / 26 mm | tk 34262-26 |

HEGAR

| | | |
|-------------------------|----|--------------------|
| Ø 3 / 4 mm - 17 / 18 mm | 8 | tk 34265-05 |
| Ø 1 / 2 mm - 25 / 26 mm | 13 | tk 34265-06 |

Stück per Satz Satz, allein
Pieces per set *Set, only*
 Pièces per jeu Jeu, seul
Piezas por juego *Juego, solo*
 Pezzi per serie Serie, solo



HEGAR

| | | | |
|-------------------------|----|--------------------|--------------------|
| Ø 3 / 4 mm - 17 / 18 mm | 8 | tk 34265-00 | tk 34265-08 |
| Ø 1 / 2 mm - 25 / 26 mm | 13 | - | tk 34265-13 |

Stück per Satz Satz in Stoffrolltasche
Pieces per set *Set in canvas roll*
 Pièces per jeu Jeu en poche de textile
Piezas por juego *Juego en bolsa de tela*
 Pezzi per serie Serie in astuccio di tela

Satz, in Metalletui
Set, in metal case
 Jeu, en boîte de métal
Juego, en caja de metal
 Serie, in astuccio metallico

Biopsieküretten
Biopsy curettes

Curettes pour biopsie
Curetas para biopsía
Curette per biopsia



RANDALL

| | |
|-------------|--------------------|
| | Ø 4 mm |
| 240mm - 9½" | tk 34800-24 |



NOVAK

| | |
|-------------|--------------------|
| | Ø 4 mm |
| 230 mm - 9" | tk 34805-23 |

MINI-NOVAK

| | |
|--------|--------------------|
| | 235 mm - 9¼" |
| Ø 1 mm | tk 34807-23 |
| Ø 2 mm | tk 34808-23 |
| Ø 3 mm | tk 34809-23 |



KEVORKIAN

| | | |
|--------------|--------------------|--------------------|
| 300 mm - 12" | tk 34810-30 | tk 34813-30 |
|--------------|--------------------|--------------------|

fest, ohne Korb
rigid, without basket
rigide, sans panier
rigida, sin cesta
rigida, senza cestino

fest, mit Korb
rigid, with basket
rigide, avec panier
rigida, con cesta
rigida, con cestino

tk 34811-30

tk 34812-30

biegsam, ohne Korb
malleable, without basket
malléable, sans panier
malleable, sin cesta
flessibile, senza cestino

biegsam, mit Korb
malleable, with basket
malléable, avec panier
malleable, con cesta
flessibile, con cestino



Endospekula | Endospéculums
 Endospecula | Endospéculos
 Endospecoli



KOGAN

240 mm - 9½" | tk 34153-24

mit Skalensperre und Stellschraube
 with scale-ratchet and fixation screw

avec crémaillère à échelle et vis à fixation
 con cremallera graduada y tornillo de fijación
 con cremagliera graduata e vite di fissaggio



KOGAN

240 mm - 9½"

tk 34154-24



KOGAN-MODIF.

280 mm - 11"

x = 4 mm y = 8 mm | tk 34150-01

x = 2 mm y = 4 mm | tk 34150-02

Hakenzangen
Uterine tenaculum forceps

Pinces pour le col d'utérus
Pinzas para coger el cuello del útero
Pinze per abbassare il collo dell'utero



BARRETT

180 mm - 7"

tk 34305-18



SCHROEDER

250 mm - 9³/₄"

tk 34310-25



POZZI

255 mm - 10"

tk 34311-26

Salpingograph | Salpingographe
Salpingograph | *Salpingógrafo*
 Salpingografo

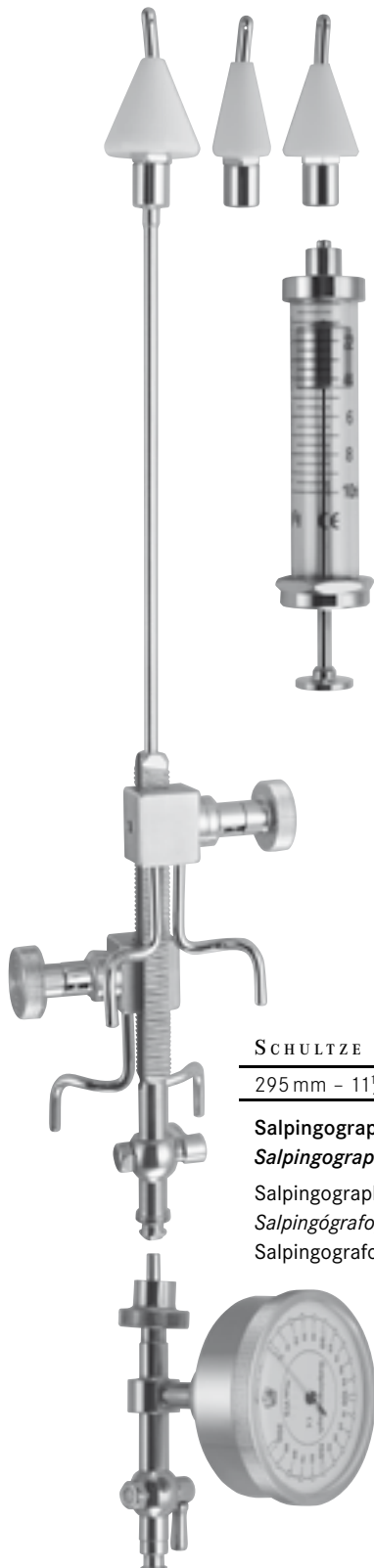

SCHULTZE
 295 mm - 11½" | **tk 34880-00**

Salpingograph, komplett im Holzetui
Salpingograph, complete in wooden case
 Salpingographe, complet en etui de bois
Salpingógrafo, completo en caja de madera
 Salpingografo, completo in astuccio di legno

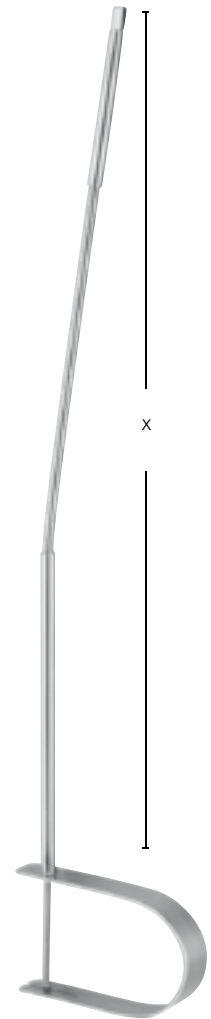

Ø 4 mm
 x = 230 mm - 9" | **tk 34872-00**

Zange zum Entfernen von Spiralen
Spiral forceps hook for I.U.D. removings
 Pince pour enlever des stérilets
Pinza para remover la espiral de esterilidad
 Pinza per rimuovere la spirale

Zubehör
Accessories

Accessoires
Accesorios
Accessori



tk 85109-10

Textilfilter für tk 85109-01

Textile filter for tk 85109-01

Filtre en textile pour tk 85109-01

Filtro de tejido para tk 85109-01

Filtro tessile per tk 85109-01

380 x 260 x 65 mm

tk 85109-01

Sterilisier Container mit Einsatz (für Resektoskopie Set, ohne Instrumente)

Sterilisation containers with insert (for resectoscopy set, without instruments)

Contenaies pour stérilisation avec insert (pour résectoscopie, sans instruments)

Contenedor para esterilización con inserto (para set de resectoscopia, sin instrumentos)

Container per sterilizzazione con inserto (per set di resettoscopia, senza strumenti)

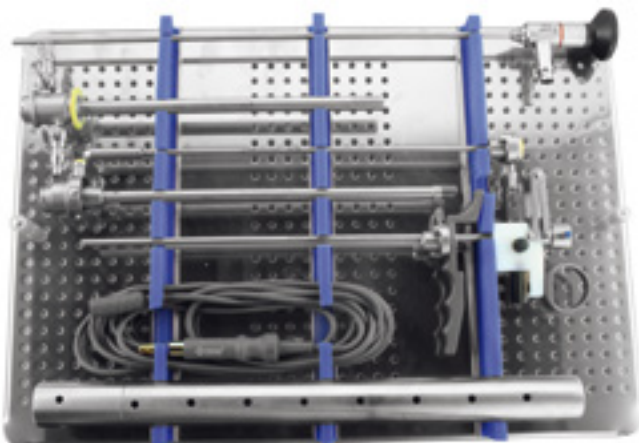

370 x 255 x 45 mm

tk 85109-02

Einsatz für Container tk 85109-01 (ohne Instrumente)

Insert for container tk 85109-01 (without instruments)

Insert pour contenaire tk 85109-01 (sans instruments)

Inserto para contenedor tk 85109-01 (sin instrumentos)

Inserto per container tk 85109-01 (senza strumenti)

**Zubehör
Accessories**

**Accessoires
Accesorios
Accessori**



Perforierter Boden und Deckel, ohne Filter.
Silikonhalterungen für zwei Endoscope.

*Perforated bottom and lid, without filter.
Silicon fittings for two endoscopes.*

Couvercle et fond perforés, sans filtres.
Pièces en silicone pour 2 optiques.

*Tapa y fondo perforados, sin filtros.
Piezas en silicona para 2 ópticas.*

Coperchio e fondo perforato, senza filtri.
Sostegno di silicone per 2 ottiche.

| | | |
|------------------|--|-----------------------|
| 250 x 60 x 50 mm | | tk 87280-2F-SI |
| 250 x 60 x 50 mm | | tk 87280-2F-YE |
| 250 x 60 x 50 mm | | tk 87280-2F-GR |
| 250 x 60 x 50 mm | | tk 87280-2F-BL |
| 250 x 60 x 50 mm | | tk 87280-2F-RE |
| 250 x 60 x 50 mm | | tk 87280-2F-BK |

Deckelfarbe
Lid colour

Couleur du couvercle
Color de la tapa
Colore del coperchio

| | | |
|------------------|--|-----------------------|
| 450 x 70 x 70 mm | | tk 87290-2F-SI |
| 450 x 70 x 70 mm | | tk 87290-2F-YE |
| 450 x 70 x 70 mm | | tk 87290-2F-GR |
| 450 x 70 x 70 mm | | tk 87290-2F-BL |
| 450 x 70 x 70 mm | | tk 87290-2F-RE |
| 450 x 70 x 70 mm | | tk 87290-2F-BK |

Deckelfarbe
Lid colour

Couleur du couvercle
Color de la tapa
Colore del coperchio



| | |
|------------------|-------------------|
| 460 x 80 x 52 mm | tk 707-650 |
| 290 x 80 x 52 mm | tk 707-651 |

Siebkorb für Optiken > ø 2,7mm
Wire basket for endoscopes > ø 2,7 mm

Panier pour optiques > ø 2,7 mm
Cesta para ópticas > ø 2,7 mm
Cestello per ottiche con > ø 2,7 mm

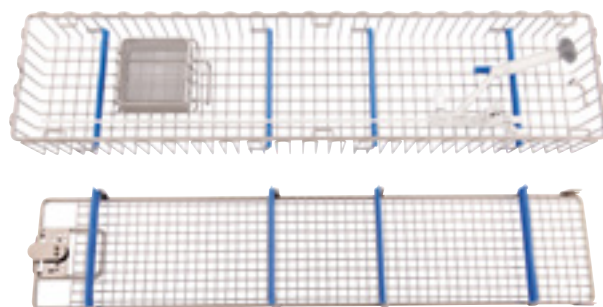

| | |
|-------------------|-------------------|
| 640 x 150 x 77 mm | tk 707-654 |
|-------------------|-------------------|

Siebkorb für Uretero-Renoskop
Wire basket for uretereo-rensoscopy

Panier pour uretero-rensoscopy
Cesta para uretero-rensoscopy
Cestello per uretero-rensoscopy



tk 700-999

Autoklavierbare Schutzhülse für Endoskope bis Ø 5 mm, durch Zusammenstecken von 2 Hülssen erweiterbar für Urologie / Gynäkologie - Optiken
Autoclavable protection tube for endoscopes up to Ø 5 mm, assembling of two tubes will allow a protection for Urology / Gynaecology scopes

Gaines de protection autoclavables pour optiques jusqu'au 5mm Ø. En combinant deux gaines, élargable pour des optiques d'urologie et gynécologie.

Vainas de protección autoclavables para ópticas fino a Ø 5mm. Conectando dos vainas se pueden utilizar también para ópticas de Urología / Ginecología

Tubi di protezione autoclavabili per ottiche fino a 5 mm fino Ø 5 mm. L'assemblaggio di due tubi consentirà la protezione delle per urologia / ginecologia

Ersatzteile, Pflegemittel
Spare parts, detergents for instruments

Pièces de réchange, détergents
Piezas de recambio, detergentes
Pezzi di ricambio, detergenti



| | 30 ml | 25 ml | 15 ml |
|---|---|---|---|
| | tk 95000-50 | tk 95000-51 | tk 95000-52 |
| Antibeslagmittel <i>Antifog solution</i> Solution antibuée <i>Solución antiraho</i> Anti appannante | Durchstichflasche (steril) <i>Pierce bottle (sterile)</i> Bouteille perforée (stérile) <i>Botella perforada (estéril)</i> Bottiglia perforata (sterile) | Pipettenflasche <i>Pipette bottle</i> Bouteille pipette <i>Botella con pipeta</i> Bottiglia con pipetta | Sprühflasche <i>Spray bottle</i> Bouteille spray <i>Botella de spray</i> Bottiglia di spray |



| | tk 95011-00 | tk 95011-02 | tk 95012-00 |
|---|---|---|--|
| LL-Verschlusschrauben <i>End screws for LL channels</i> Vis pour connecteur LL <i>Tornillos para conexión LL</i> Tappi di chiusura LL | Kunststoff weiß <i>Plastic, white</i> Plastifié, blanc <i>Plástico blanco</i> Plastica bianca | Silikon schwarz <i>Silicone, black</i> Silicone, noir <i>Silicona negro</i> Silicone nero | Edelstahl <i>Stainless steel</i> Acier inoxydable <i>Acero inoxidable</i> Acciaio inossidabile |



tk 95010-00

Dichtungskappe, Silikon, (10 Stück)
Silicon cap, (10 pieces)
Capuchon de silicón, (10 pièces.)
Capuchón de sílica, (10 piezas)
Tappo in silicone, (10 pezzi)



tk 95000-20

Hahnenfett, 5g
Grease for stopcocks, 5g
Graisse pour robinets, 5g
Grasa para robinetes, 5g
Grasso per rubinette, 5g

Zubehör | Accessoires
Accessories | Accesorios
Accessori



| | |
|--------------------|--------------------|
| 500 ml | 100 ml |
| tk 95000-00 | tk 95100-00 |

TEKNO spezial Öl zur Instrumentenpflege
TEKNO special oil for surgical instruments

TEKNO huileux pour des instruments
TEKNO aceite para instrumentos

TEKNO olio speciale per strumentario chirurgico



tk 790-399

LUER-Lock Schlauchverbindung mit Hahn
LUER-Lock tube connector with stopcock

LUER-Lock raccord avec robinet

LUER-Lock conector para tubos con grifo

LUER-Lock raccordo con rubinetto d'arresto



tk 790-398

LUER-Lock Schlauchverbindung
LUER-Lock tube connector

LUER-Lock raccord

LUER-Lock conector para tubos

LUER-Lock raccordo

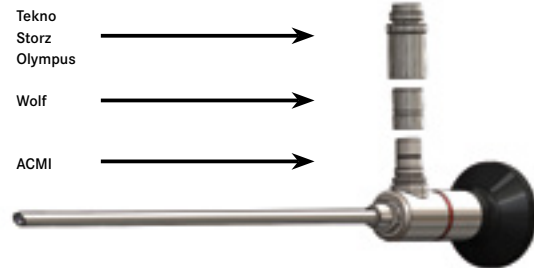

tk 700-997

Adapter für TEKNO Optiken zum Anschluss von
TEKNO, Storz und Olympus Kaltlichtkabeln.
*Adaptor for TEKNO endoscopes to connect TEKNO,
Storz, Olympus cold light cables.*

Adaptateur pour connecter des optiques TEKNO
avec des cables de lumière froide TEKNO, Storz, Olympus
*Adaptador para la conexión de las ópticas TEKNO
con los cables de luz fría de TEKNO, Storz, Olympus*
Adattatore per ottiche TEKNO per la connessione
con cavi di luce fredda TEKNO, Storz ed Olympus



tk 700-998

Adapter für TEKNO Optiken zum Anschluss von
Wolf Kaltlichtkabeln.
*Adaptor for TEKNO endoscopes to connect Wolf
cold light cables.*

Adaptateur pour connecter des optiques TEKNO
avec des cables de lumière froide Wolf
*Adaptador para la conexión de las ópticas TEKNO
con los cables de luz fría de Wolf*
Adattatore per ottiche TEKNO per la connessione
con cavi di luce fredda Wolf

TEKNO-FLEX

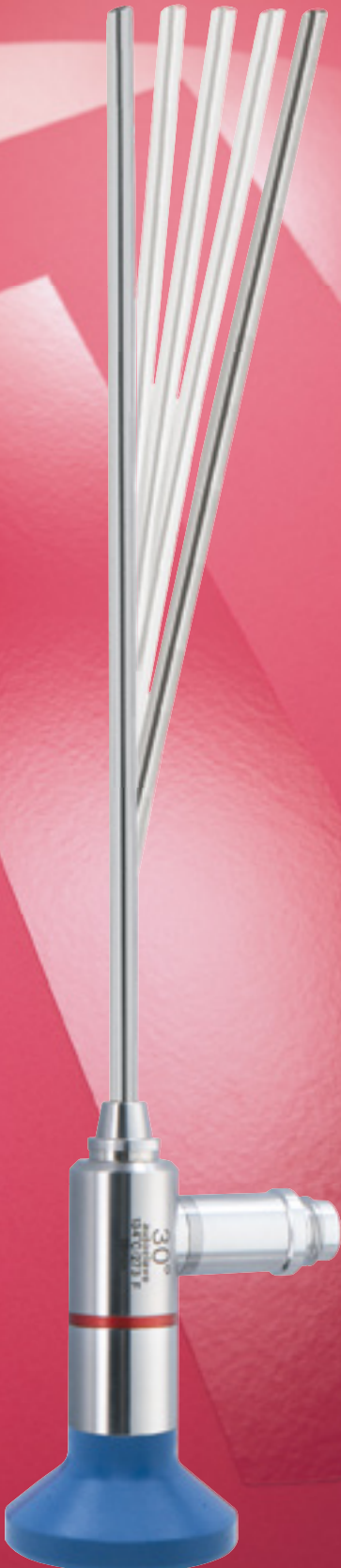

Die Vorteile von Tekno-Flex Endoskope (patentiert):

- weniger anfällig gegen äußere mechanische Einwirkungen, wie Verbiegen
- höhere Flexibilität im Vergleich zu Standard Endoskopen
- höhere Widerstandsfähigkeit (70% aller Reparaturen basieren auf gebrochenen Stablinsen, verursacht durch gebogene Schäfte)
- kratzsicheres Saphirglas am distalen Ende und am Okular
- korrekte Farbwiedergabe und gleichmäßige Bildschärfe
- 1 Jahr Garantie auf gebrochene Stablinsen
- Tekno-Flex Optiken sind durch den Zusatz "SF" gekennzeichnet

The advantages of Tekno-Flex endoscopes (patented):

- *the optical system is less sensitive to bending*
- *higher flexibility compared to standard rigid endoscopes*
- *higher robustness (70% of all repairing is due to broken rod-lenses caused by bent tubes)*
- *scratch-proof sapphire glass on the distal end and ocular side*
- *high resolution and contrast reproduction*
- *1 year warranty against broken rod-lenses*
- *Tekno-Flex scopes can be recognized by the suffix "SF"*

Les avantages des endoscopes Tekno-Flex (brevetés):

- haute résistance contre influences mécaniques
- meilleure souplesse comparé avec des endoscopes rigides
- meilleure résistance (70% de toutes réparations sont provoquées par des ruptures des lentilles cylindriques)
- verres distales et proximales en saphir
- reproduction parfaite des couleurs et profondeur de champ exceptionnel
- 1 an de garantie sur ruptures des lentilles cylindriques
- les optiques Teko-Flex peuvent être reconnues par l'annexe "SF"

Las ventajas de los endoscopios Tekno-Flex (patentados):

- *gran resistencia al estrés mecánico*
- *mayor flexibilidad en comparación a ópticas tradicionales*
- *mayor resistencia (70% de todas las reparaciones son debidas a roturas de lentes cilíndricas)*
- *las lentes distales y proximales son de zafiro de alta resistencia*
- *perfecta reproducción de color y extraordinaria profundidad de campo*
- *1 año de garantía sobre roturas de lentes cilíndricas*
- *las ópticas Tekno-Flex son reconocidos por el anexo "SF"*

I vantaggi degli endoscopi Tekno-Flex (brevettato):

- maggiore resistenza contro stress meccanico
- accetta una grande flessione rispetto ad ottiche tradizionali
- elevata robustezza (70% di tutte le riparazioni é dovuto a rotture delle rod-lenses)
- lenti distale e prossimale in zaffiro ad alta resistenza
- perfetta riproduzione dei colori e immagine a fuoco a tutto campo
- 1 anno di garanzia su rottura delle rod-lens
- le ottiche Tekno-Flex hanno un numero d'articolo con "SF" aggiunto

Nummernverzeichnis
Numerical index

Index numériques

Indice numerico

Indice dei numeri d'articolo

| Art. No. | Page | Art. No. | Page | Art. No. | Page | Art. No. | Page |
|-------------|--------|--------------|--------|--------------|---------------|------------|--------|
| tk 30410-06 | 54, 56 | tk 34251-65 | 57 | tk 700-062SF | 12, 32 | tk 790-194 | 26 |
| tk 30410-07 | 56 | tk 34251-70 | 57 | tk 700-063 | 12, 32 | tk 790-196 | 25 |
| tk 30410-08 | 56 | tk 34251-75 | 57 | tk 700-063SF | 12, 32 | tk 790-197 | 24 |
| tk 30410-09 | 56 | tk 34251-80 | 57 | tk 700-067 | 32 | tk 790-198 | 24 |
| tk 30410-10 | 56 | tk 34251-85 | 57 | tk 700-070 | 18, 32, 42 | tk 790-199 | 24 |
| tk 30410-11 | 56 | tk 34251-90 | 57 | tk 700-070SF | 18, 32, 42 | tk 790-200 | 25 |
| tk 30410-12 | 56 | tk 34251-95 | 57 | tk 700-072 | 18, 32, 42 | tk 790-201 | 25 |
| tk 30410-13 | 56 | tk 34252-00 | 57 | tk 700-072SF | 18, 32, 42 | tk 790-202 | 24 |
| tk 30410-14 | 56 | tk 34252-10 | 57 | tk 700-073 | 5, 18, 32, 42 | tk 790-203 | 24 |
| tk 30410-15 | 56 | tk 34252-20 | 57 | tk 700-073SF | 18, 32 | tk 790-204 | 24 |
| tk 30410-16 | 56 | tk 34252-30 | 57 | tk 700-077 | 18, 32 | tk 790-205 | 24 |
| tk 30410-17 | 56 | tk 34252-40 | 57 | tk 700-077SF | 18, 32 | tk 790-206 | 24 |
| tk 30410-18 | 56 | tk 34252-50 | 57 | tk 700-081 | 12, 32, 42 | tk 790-207 | 24 |
| tk 30410-19 | 56 | tk 34252-60 | 57 | tk 700-082 | 12, 32, 42 | tk 790-216 | 25 |
| tk 30410-20 | 56 | tk 34252-70 | 57 | tk 700-085 | 12, 32, 42 | tk 790-217 | 24 |
| tk 30410-21 | 56 | tk 34252-80 | 57 | tk 700-220 | 8 | tk 790-218 | 24 |
| tk 30410-22 | 56 | tk 34252-90 | 57 | tk 700-221 | 8 | tk 790-219 | 24 |
| tk 30410-23 | 56 | tk 34253-00 | 57 | tk 700-226 | 8 | tk 790-220 | 25 |
| tk 30410-24 | 56 | tk 34260-14 | 57 | tk 700-227 | 8 | tk 790-221 | 25 |
| tk 34150-01 | 61 | tk 34260-26 | 57 | tk 700-250 | 51 | tk 790-222 | 24 |
| tk 34150-02 | 61 | tk 34261-14 | 58 | tk 700-251 | 51 | tk 790-223 | 24 |
| tk 34153-24 | 61 | tk 34261-26 | 58 | tk 700-255 | 51 | tk 790-224 | 24 |
| tk 34154-24 | 61 | tk 34261-27 | 58 | tk 700-256 | 51 | tk 790-225 | 24 |
| tk 34197-25 | 55 | tk 34261-28 | 57 | tk 700-997 | 67 | tk 790-226 | 24 |
| tk 34198-32 | 55 | tk 34262-02 | 59 | tk 700-998 | 67 | tk 790-227 | 24 |
| tk 34199-32 | 55 | tk 34262-04 | 59 | tk 700-999 | 65 | tk 790-236 | 25 |
| tk 34200-32 | 55 | tk 34262-06 | 59 | tk 707-300 | 27 | tk 790-237 | 24 |
| tk 34201-32 | 55 | tk 34262-08 | 59 | tk 707-301 | 27 | tk 790-238 | 24 |
| tk 34250-10 | 57 | tk 34262-10 | 59 | tk 707-302 | 27 | tk 790-239 | 24 |
| tk 34250-15 | 57 | tk 34262-12 | 59 | tk 707-303 | 27 | tk 790-240 | 25 |
| tk 34250-20 | 57 | tk 34262-14 | 59 | tk 707-330 | 27 | tk 790-241 | 25 |
| tk 34250-25 | 57 | tk 34262-16 | 59 | tk 707-331 | 27 | tk 790-242 | 24 |
| tk 34250-30 | 57 | tk 34262-18 | 59 | tk 707-332 | 27 | tk 790-243 | 24 |
| tk 34250-35 | 57 | tk 34262-20 | 59 | tk 707-333 | 27 | tk 790-244 | 24 |
| tk 34250-40 | 57 | tk 34262-22 | 59 | tk 707-338 | 27 | tk 790-245 | 24 |
| tk 34250-45 | 57 | tk 34262-24 | 59 | tk 707-350 | 45 | tk 790-246 | 24 |
| tk 34250-50 | 57 | tk 34262-26 | 59 | tk 707-650 | 65 | tk 790-247 | 24 |
| tk 34250-55 | 57 | tk 34265-00 | 59 | tk 707-651 | 65 | tk 790-250 | 25 |
| tk 34250-60 | 57 | tk 34265-05 | 59 | tk 707-654 | 65 | tk 790-251 | 25 |
| tk 34250-65 | 57 | tk 34265-06 | 59 | tk 790-035 | 5 | tk 790-255 | 25 |
| tk 34250-70 | 57 | tk 34265-08 | 59 | tk 790-150 | 27 | tk 790-256 | 25 |
| tk 34250-75 | 57 | tk 34265-13 | 59 | tk 790-151 | 27 | tk 790-258 | 25 |
| tk 34250-80 | 57 | tk 34305-18 | 62 | tk 790-152 | 27 | tk 790-260 | 25 |
| tk 34250-85 | 57 | tk 34310-25 | 62 | tk 790-153 | 27 | tk 790-262 | 25 |
| tk 34250-90 | 57 | tk 34311-26 | 62 | tk 790-169 | 26 | tk 790-263 | 25 |
| tk 34250-95 | 57 | tk 34800-24 | 60 | tk 790-170 | 26 | tk 790-264 | 25 |
| tk 34251-00 | 57 | tk 34805-23 | 60 | tk 790-171 | 26 | tk 790-280 | 26 |
| tk 34251-05 | 57 | tk 34807-23 | 60 | tk 790-172 | 26 | tk 790-281 | 26 |
| tk 34251-10 | 57 | tk 34808-23 | 60 | tk 790-173 | 26 | tk 790-282 | 26 |
| tk 34251-15 | 57 | tk 34809-23 | 60 | tk 790-174 | 26 | tk 790-284 | 26 |
| tk 34251-20 | 57 | tk 34810-30 | 60 | tk 790-175 | 26 | tk 790-285 | 26 |
| tk 34251-25 | 57 | tk 34811-30 | 60 | tk 790-176 | 26 | tk 790-288 | 26 |
| tk 34251-30 | 57 | tk 34812-30 | 60 | tk 790-177 | 26 | tk 790-289 | 26 |
| tk 34251-35 | 57 | tk 34813-30 | 60 | tk 790-178 | 26 | tk 790-300 | 33 |
| tk 34251-40 | 57 | tk 34872-00 | 63 | tk 790-179 | 26 | tk 790-305 | 33 |
| tk 34251-45 | 57 | tk 34880-00 | 63 | tk 790-180 | 26 | tk 790-308 | 33 |
| tk 34251-50 | 57 | tk 700-060 | 12, 32 | tk 790-186 | 26 | tk 790-309 | 33 |
| tk 34251-55 | 57 | tk 700-060SF | 12, 32 | tk 790-187 | 26 | tk 790-310 | 26, 32 |
| tk 34251-60 | 57 | tk 700-062 | 12, 32 | tk 790-189 | 26 | tk 790-311 | 26, 32 |

Nummernverzeichnis
Numerical index
Index numériques
Indice numerico
Indice dei numeri d'articolo

| Art. No. | Page | Art. No. | Page | Art. No. | Page | Art. No. | Page |
|------------|------------|------------|------|-------------|------------|----------------|------|
| tk 790-312 | 26, 32 | tk 791-048 | 16 | tk 791-258 | 8 | tk 799-356 | 47 |
| tk 790-313 | 26, 32 | tk 791-049 | 16 | tk 791-350 | 34 | tk 799-357 | 47 |
| tk 790-315 | 36 | tk 791-050 | 9 | tk 791-351 | 34 | tk 799-360 | 47 |
| tk 790-316 | 36 | tk 791-051 | 9 | tk 791-352 | 34 | tk 799-361 | 46 |
| tk 790-317 | 36 | tk 791-052 | 9 | tk 791-353 | 34 | tk 799-362 | 46 |
| tk 790-318 | 36, 37, 38 | tk 791-053 | 9 | tk 791-354 | 35 | tk 799-365 | 47 |
| tk 790-320 | 37 | tk 791-055 | 10 | tk 791-355 | 35 | tk 799-366 | 47 |
| tk 790-321 | 37 | tk 791-056 | 10 | tk 791-357 | 34 | tk 799-367 | 47 |
| tk 790-322 | 37 | tk 791-057 | 11 | tk 791-358 | 34 | tk 799-372 | 46 |
| tk 790-323 | 36, 37, 38 | tk 791-058 | 11 | tk 791-359 | 35 | tk 799-372S | 46 |
| tk 790-324 | 36, 38 | tk 791-060 | 20 | tk 791-363 | 35 | tk 799-373 | 46 |
| tk 790-327 | 38 | tk 791-061 | 20 | tk 791-365 | 35 | tk 799-373S | 46 |
| tk 790-330 | 36 | tk 791-063 | 20 | tk 791-367 | 35 | tk 799-374 | 46 |
| tk 790-331 | 36 | tk 791-064 | 20 | tk 791-420 | 34 | tk 799-378 | 46 |
| tk 790-332 | 36 | tk 791-065 | 20 | tk 791-421 | 34 | tk 799-577 | 43 |
| tk 790-341 | 36 | tk 791-070 | 22 | tk 791-422 | 35 | tk 799-578 | 43 |
| tk 790-343 | 36 | tk 791-072 | 22 | tk 791-423 | 35 | tk 799-579 | 43 |
| tk 790-344 | 36 | tk 791-074 | 22 | tk 791-424 | 34 | tk 85109-01 | 64 |
| tk 790-345 | 38 | tk 791-076 | 22 | tk 791-450 | 34 | tk 85109-02 | 64 |
| tk 790-374 | 35 | tk 791-077 | 14 | tk 791-451 | 34 | tk 85109-10 | 64 |
| tk 790-398 | 67 | tk 791-078 | 14 | tk 791-452 | 34 | tk 87280-2F-BK | 65 |
| tk 790-399 | 67 | tk 791-079 | 14 | tk 791-453 | 34 | tk 87280-2F-BL | 65 |
| tk 790-482 | 26 | tk 791-080 | 15 | tk 791-454 | 35 | tk 87280-2F-GR | 65 |
| tk 790-483 | 26 | tk 791-081 | 15 | tk 791-455 | 35 | tk 87280-2F-RE | 65 |
| tk 790-484 | 26 | tk 791-130 | 18 | tk 791-457 | 34 | tk 87280-2F-SI | 65 |
| tk 790-485 | 26 | tk 791-131 | 18 | tk 791-458 | 34 | tk 87280-2F-YE | 65 |
| tk 790-486 | 26 | tk 791-132 | 19 | tk 791-463 | 35 | tk 87290-2F-BK | 65 |
| tk 790-487 | 26 | tk 791-133 | 19 | tk 791-465 | 35 | tk 87290-2F-BL | 65 |
| tk 790-488 | 26 | tk 791-134 | 21 | tk 791-467 | 35 | tk 87290-2F-GR | 65 |
| tk 790-490 | 37 | tk 791-136 | 21 | tk 799-300 | 45 | tk 87290-2F-RE | 65 |
| tk 790-491 | 37 | tk 791-137 | 19 | tk 799-305 | 45 | tk 87290-2F-SI | 65 |
| tk 790-492 | 37 | tk 791-138 | 19 | tk 799-308 | 45 | tk 87290-2F-YE | 65 |
| tk 790-495 | 26 | tk 791-140 | 21 | tk 799-309 | 45 | tk 95000-00 | 67 |
| tk 790-496 | 26 | tk 791-142 | 23 | tk 799-310 | 48 | tk 95000-20 | 66 |
| tk 790-498 | 38 | tk 791-143 | 23 | tk 799-311 | 48 | tk 95000-50 | 66 |
| tk 790-570 | 43 | tk 791-144 | 23 | tk 799-312 | 48 | tk 95000-51 | 66 |
| tk 790-572 | 44 | tk 791-150 | 53 | tk 799-313 | 48, 59 | tk 95000-52 | 66 |
| tk 790-573 | 44 | tk 791-151 | 53 | tk 799-320 | 49 | tk 95010-00 | 66 |
| tk 790-574 | 44 | tk 791-152 | 53 | tk 799-321 | 49 | tk 95011-00 | 66 |
| tk 790-575 | 44 | tk 791-153 | 53 | tk 799-322 | 49 | tk 95011-02 | 66 |
| tk 790-726 | 38 | tk 791-154 | 53 | tk 799-323 | 48, 49, 50 | tk 95012-00 | 66 |
| tk 790-727 | 38 | tk 791-155 | 53 | tk 799-324 | 49 | tk 95100-00 | 67 |
| tk 791-024 | 15 | tk 791-156 | 53 | tk 799-326 | 50 | | |
| tk 791-026 | 15 | tk 791-157 | 53 | tk 799-327 | 50 | | |
| tk 791-030 | 13 | tk 791-161 | 54 | tk 799-328 | 49 | | |
| tk 791-031 | 13 | tk 791-170 | 54 | tk 799-330 | 48 | | |
| tk 791-032 | 13 | tk 791-174 | 54 | tk 799-331 | 48 | | |
| tk 791-033 | 13 | tk 791-175 | 54 | tk 799-332 | 48 | | |
| tk 791-034 | 14 | tk 791-176 | 54 | tk 799-333 | 48 | | |
| tk 791-035 | 14 | tk 791-180 | 52 | tk 799-335 | 48 | | |
| tk 791-037 | 14 | tk 791-185 | 52 | tk 799-345 | 50 | | |
| tk 791-040 | 14 | tk 791-187 | 52 | tk 799-350 | 47 | | |
| tk 791-041 | 14 | tk 791-189 | 52 | tk 799-350S | 47 | | |
| tk 791-042 | 10 | tk 791-250 | 8 | tk 799-351 | 46 | | |
| tk 791-043 | 20 | tk 791-251 | 8 | tk 799-352 | 46 | | |
| tk 791-044 | 14 | tk 791-252 | 12 | tk 799-353 | 46 | | |
| tk 791-045 | 17 | tk 791-253 | 12 | tk 799-354 | 47 | | |
| tk 791-046 | 17 | tk 791-256 | 18 | tk 799-355 | 47 | | |
| tk 791-047 | 16 | tk 791-257 | 12 | tk 799-355S | 47 | | |

| | |
|----------------|--------------|
| Notizen | Notices |
| <i>Notes</i> | <i>Notas</i> |
| | Note |

| | |
|----------------|--------------|
| Notizen | Notices |
| <i>Notes</i> | <i>Notas</i> |
| | Note |

Wichtige Hinweise

Dieser Katalog bleibt Eigentum der Firma TEKNO-MEDICAL Optik-Chirurgie GmbH, auch wenn dafür eine Schutzgebühr bezahlt wurde. Er kann von uns jederzeit zurückgefordert werden, wenn er gegen unsere Interessen und nicht zum Vertrieb und Einkauf von TEKNO Produkten verwendet wird. Auch behalten wir uns in solch einem Falle weitergehende Maßnahmen vor.

Der Nachdruck oder Kopieren dieses Kataloges – im Gesamten oder auch nur auszugsweise – ist ohne unsere schriftliche Genehmigung verboten.

Modelländerungen vorbehalten. Gedruckt in der Bundesrepublik Deutschland

Important notice

This catalogue remains property of TEKNO-MEDICAL Optik-Chirurgie GmbH even if we have asked for a lending fee or charges. We can at any time recall the catalogue, in case that it has been not used according to our interests, i.e. sale or purchase of TEKNO products. We preserve the right for further steps in that case.

Reproduction or copying of this catalogue in whole or in parts is forbidden without our written permission.

Patterns are subject to change. Printed in Germany

Indications importantes

Ce catalogue reste la propriété de TEKNO-MEDICAL Optik-Chirurgie GmbH, même si nous avons demandé le paiement d'une taxe de protection. Nous pouvons demander le retour du catalogue dans le cas où celui-ci n'est pas utilisé conformément à nos intérêts, pour la vente ou l'achat de nos produits. Dans ce cas nous nous réservons le droit de mener des actions juridiques.

La reproduction ou la copie totale ou partielle de ce catalogue est interdite sans notre accord écrit.

Sous réserve des modifications techniques. Imprimé en Allemagne

Avisos importantes

Este catálogo es propiedad de TEKNO-MEDICAL Optik-Chirurgie GmbH, aún en el caso de haber abonado por él una tasa de colaboración. Podemos solicitar la devolución del catálogo en caso de que no sea utilizado para la compra o venta de nuestros productos. En este caso nos reservamos el derecho de tomar medidas jurídicas.

La reproducción o copia total o parcial de este catálogo esta prohibido sin nuestro consentimiento escrito.

Salvo modificaciones técnicas. Impreso en la República Federal de Alemania

Avvertenze importanti

Questo catalogo rimane proprietà della TEKNO-MEDICAL Optik-Chirurgie GmbH, anche se è stato rilasciato gratuitamente o contro pagamento. Possiamo in ogni momento richiederlo indietro, in caso non stato usato in accordo con i nostri interessi (acquisto e vendita dei prodotti TEKNO-Medical). Ci riserviamo in questo caso il diritto di prendere ulteriori provvedimenti.

La copia o la riproduzione di questo catalogo in parte o nella sua totalità è vietata senza il nostro permesso scritto.

Ci riserviamo la facoltà di cambiamenti nei modelli. Stampato in Germania



TEKNO-MEDICAL Optik-Chirurgie GmbH

Sattlerstrasse 11 · 78532 Tuttlingen, Germany
Telefon +49 (74 61) 17 01-0 · Fax +49 (74 61) 17 01-50
mail@tekno-medical.com · www.tekno-medical.com

© 09.2015 - TEKNO-MEDICAL Optik-Chirurgie GmbH
TEKNO is a registered trademark of TEKNO-MEDICAL Optik-Chirurgie GmbH